

XFP 16 Zone Repeater Panel (all protocols)

Part No. **XFP510-16**

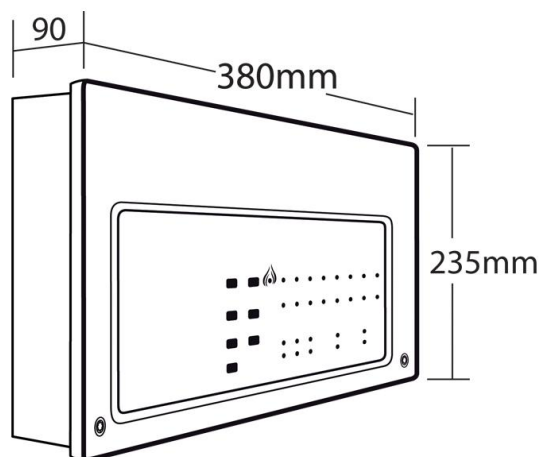

Overview

Can be used to repeat the functions of an XFP Main panel at remote parts of a site (e.g. all potential fire service entrances).

Offers all of the functions and controls of an XFP Main panel (access levels 1, 2 and 3).

Includes an on-board fault relay.

Requires its own dedicated Mains power and battery back-up supply.

A maximum of eight XFP Repeaters can be connected to one non-networked XFP Main panel.

Communication between the XFP Main panel and Repeater requires a CFP761 network driver card (fitted as standard in all XFP510-16s, available as an optional extra on Main XFP 16 Zone panels).

Repeater network wired in 1.5 mm² two-core screened fire resistant cable. Network length must not exceed 500 metres.

Technical Specifications

Protocol/compatibility	Compatible with C-TEC's XFP CAST, Apollo XP95/Discovery and Hochiki ESP main panels.
Mains supply	230V 50/60Hz.
Mains rated current	350mA maximum.
Internal power supply	27Vdc nominal.
Total output current limited to	1.4A @ 230Vac (Imax.A 210mA; Imin. 40mA).
Quiescent current	TBC.
Max battery size and type	2 x 12V 3.2Ah VRLA connected in series.
Auxiliary relays	Fault (Failsafe; Capable of switching 1A @ 30V DC; Must not be used for switching Mains voltages).
PC connection	None.
Indicators	2 line x 40 character backlit display; 16 Zonal LEDs, General Fire; Energised; Pre-Alarm; Remote Output Activated; Remote Output Disabled; Accessed; Disablement; Test; Silenced; General Fault; System Fault.
Expansion connections	On board CFP761 network driver card facilitates the connection of additional XFP Repeaters.



Product dimensions (mm)	380 W x 235 H x D 96mm;
Construction & finish	Plastic lid and base; RAL7035 textured.
IP Rating	IP30.
Weight	1.8kg (without batteries).
Network specification	Max. no. of Repeaters per Main XFP: 8 (any mix); Max. total length of Repeater network: 500m; Cabling requirements: 1.5mm ² two core screened fire resistant.
Operating conditions/temperature	-5°C to +40°C. Max relative humidity: 95%.



T 01942 322744 E sales@c-tec.co.uk
F 01942 829867 W www.c-tec.com



C-TEC, Challenge Way, Martland Park, Wigan, WN5 0LD United Kingdom