



ELMDENE
Security & Fire
Products



Setting reed - Normally Open (N.O.) or Normally Closed (N.C.)

Default is set to Normally closed. Please skip this section if this is the required setting.

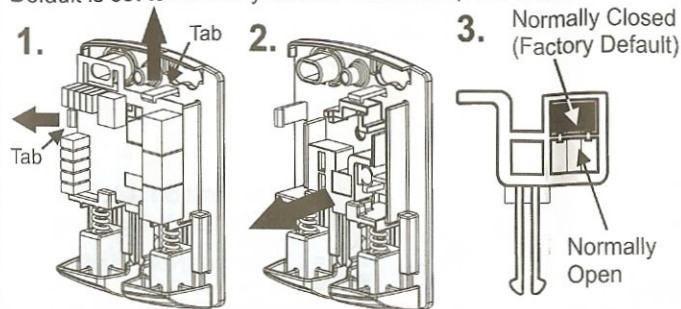

1. Remove PCB by gently bending the two tabs back and pull the board up and out.
2. Remove the sliding mechanism (you may need to loosen the friction adjustment screw).
3. Push out magnet from other side and swap to desired position.

Follow steps 1&2 in reverse order to re-assemble. Take care not to damage the reed switch.

Wall Mounting

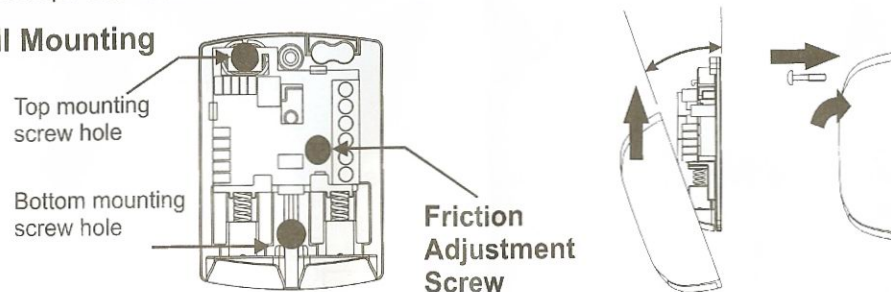

1. Press both buttons to move mechanism out of the way and gain access to the bottom fixing hole.
2. Mark positions of holes on the wall.
3. Drill holes to required depth and use appropriate wall plugs or fixings (No. 6 / 5mm).
4. Drive bottom **countersunk** screw through base and into wall.
5. Insert top **pan head** screw through PCB and plastic and screw into wall. **Take care not to snap the PCB tamper breakout.**
6. Use friction adjustment screw to ensure sliding mechanism does not move without being pushed by buttons or reset key. **DO NOT OVERTIGHTEN**
7. Angle lid as shown above. Slide upward **before** pushing lid closed. Fasten lid shut with screw.

Removing/Replacing the key

1. Remove key cover as shown.
2. Pull the key upwards and out of the housing.
To replace the key push it back into the housing and replace the cap.
Ensure the key is oriented correctly (see picture).

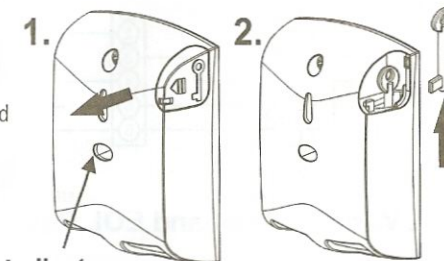

Use of the PA button

1. Push both buttons together to operate. After use indicator will be red (latched).
2. To reset insert the key into the slot as shown.
3. Turn key clockwise as far as it will turn (about 120 degrees) to reset the PA.
4. Turn the key anticlockwise back to the start and remove it.
5. Indicator will now be yellow (ready).

Indicator window

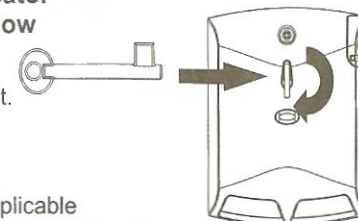

Correct Use of PA Buttons

PA buttons should be installed in accordance with any applicable regulations relating to panic alarms. Potential users should be advised in the use of the PA.

ELM-PA-G3-X Panic Button Guide

X is colour code: ELM-PA-G3-W White, ELM-PA-G3-B Brass, ELM-PA-G3-SS Steel

Panic alarm trigger device with two push buttons

Meets the requirements of PD6662: 2004, BS 4737-3.14: 1986 and EN 50131-1:2006 Grade 3, Environmental class II.

A range of aesthetically pleasing two button panic alarm (PA) devices available with white, brass or stainless steel appearance covers. Suitable for commercial and domestic installation.

Features include:

- Silent two button operation
- Compliant with PD6662: 2004 +A1 + A2, meeting BS 4737-3.14: 1986, type Y or Z, and requirements of EN 50131-1:2006, Security grade 3, Environmental class II.
- Suitable for use under the ACPO "10 point plan" for false PA reduction
- Integral, selectable resistor values for easy FSL connection to most alarm control panels.
- Alternative double pole wiring option
- Spare terminals for connection of multiple units
- Key operated mechanical reset
- Integral storage for reset key with colour matched cover
- Selectable normally open or normally closed alarm contacts
- Cover and removal from wall tamper (normally closed)
- Visual indication of ready or latched state

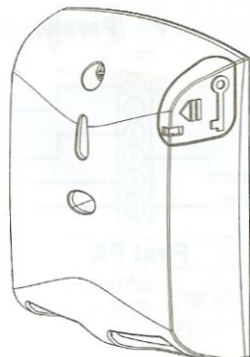

Specifications

Temperature Range -10°C to +40°C
Dimensions 62 x 80 x 27mm

Contact
Power Handling 10VA
Voltage Rating 30Vdc
Current Rating 1.0A Max
Resistance <300mohms
Operating Life >1 x 10⁸ operations

Wiring the PA Button

Connections to the PA button are made via the screw terminals numbered 1 to 6. Configuration of the resistor values to match the alarm panel is by link jumpers. See the table below to find the resistor values and series or parallel option needed.

Location of Configuration Parts

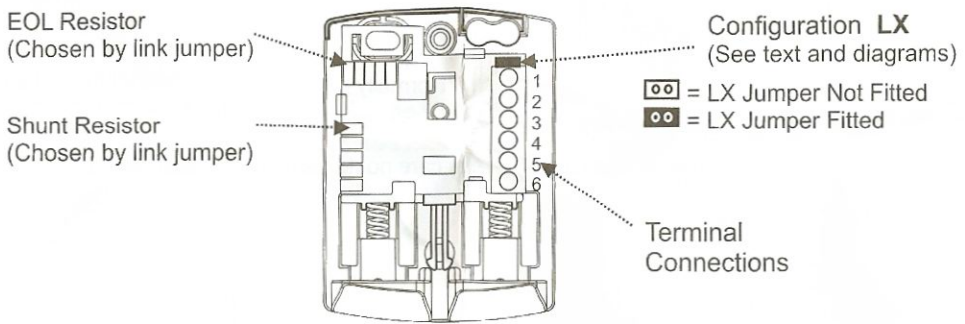

Double Pole Wiring - REMOVE ALL JUMPERS

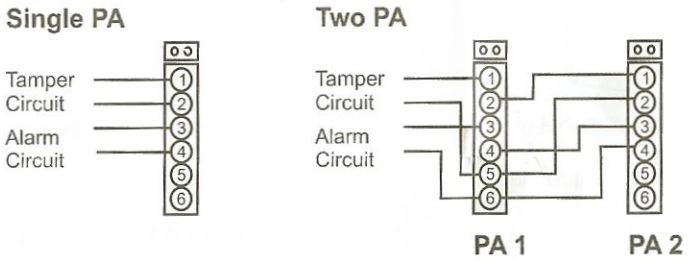

Double Pole Wiring - REMOVE ALL JUMPERS

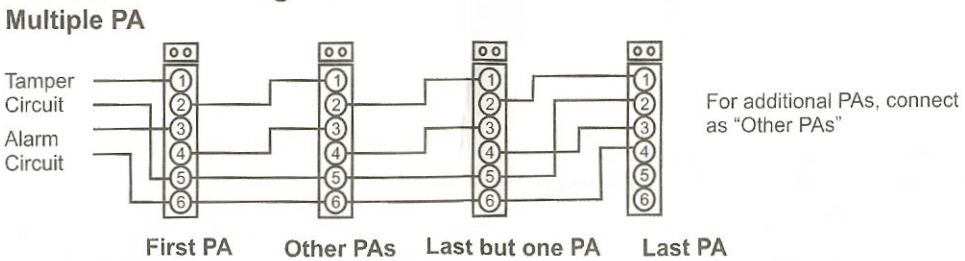

FSL Wiring (Shunt and EOL Resistor)

Shunt and EOL Resistors by Control Panel Manufacturer

Control Panel	Shunt Resistor	EOL Resistor	Configuration
ADE, Bosch, Castle, Menvier, Pyronix, Scantronic, Texecom	4k7	2k2	Series
Honeywell (Galaxy)	1k0	1k0	Series
Guardall	8k2	8k2	Parallel
GE, Aritech, Pyronix	4k7	4k7	Series
Gardtec	6k8	4k7	Series
Bosch, Europlex	2k2	2k2	Series
DSC	5k6	5k6	Series

FSL Wiring

Single PA (Parallel or Series)

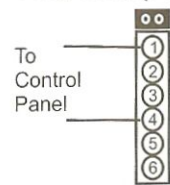

Jumper Settings	Shunt R	EOL R	LX
	✓	✓	✓

Two PA (Series Resistor Configuration)

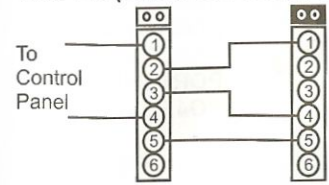

Jumper Settings	PA 1	PA 2
Shunt R	✓	✗
EOL R	✗	✓
LX	✗	✓

Multiple PA (Series Resistor Configuration)

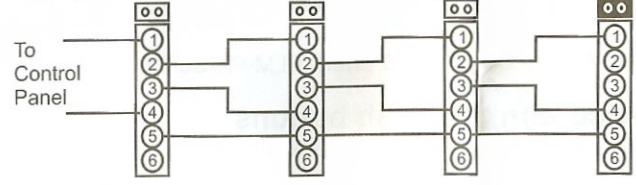

Jumper Settings	First PA	Second PA	Other PAs	Last PA
Shunt R	✓	✗	✗	✗
EOL R	✗	✗	✗	✓
LX	✗	✗	✗	✓

For additional PAs, connect as "Other PAs"

Two PA (Parallel Resistor Configuration)

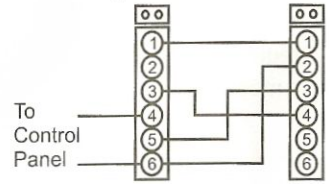

Jumper Settings	PA 1	PA 2
Shunt R	✓	✗
EOL R	✓	✗
LX	✗	✗

Follow Instructions
 ✓ = Fit jumper shown
 ✗ = Do Not Fit jumper
 LX = Link near terminal 1

Legend:
 ○○ = LX Jumper Not Fitted
 ●● = LX Jumper Fitted

Multiple PA (Parallel Resistor Configuration)

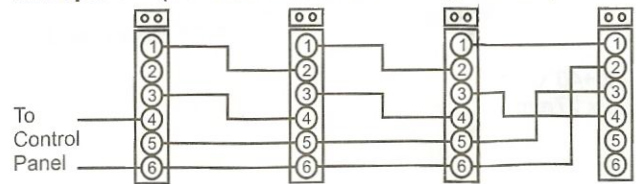

Jumper Settings	First PA	Other PAs	Last but one PA	Last PA
Shunt R	✓	✗	✗	✗
EOL R	✓	✗	✗	✗
LX	✗	✗	✗	✗

For additional PAs, connect as "Other PAs"