

Control panel types available on this model.

Type	Control Panel	Colour	Alarm	Tamper
A	Honeywell, Ademco Microtech	Green	1K	1K
B	Scantronic, Menvier, Pyronix PCX (12, 22, 44, 128 VID), Texecom, Castle CareTech G3 Plus.	Red	4K7	2K2
D	DSC	Orange	5K6	5K6
E	Guardtec	Purple	6K8	4K7
I*	Pyronix Matrix, PCX SMS, 134, 256.	Varies	4K7	4K7

* Please note that type I (4K7 : 4K7) is achieved by selecting the alarm link of type B and the tamper link of type E

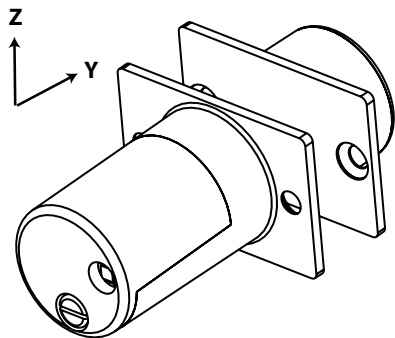

**Aprox Operating Distances (mm)
Non Ferrous Surface**

Z	Min Close	15mm
	Max Open	25mm
Y	Min Close	9mm
	Max Open	16mm

Mounting on a ferrous surface will reduce these figures, dependant on the material and thickness.

Specifications

Switch		Housing	
Contact Material:	Rhodium	Material:	High Impact Polystyrene
Contact Rating:	500mA @ 12Vdc	Contact Dimension (mm):	33 x 22 x 32
Contact Resistance:	100 milliOhms	Contact Fixing (mm):	26mm centres
Temperature Range:	-15° C to +40° C	Magnet Dimension (mm):	33 x 22 x 13
Life Expectancy:	>1,000,000 cycles	Magnet fixing (mm)	26mm centres

Environmental Advice.

This product is covered by current WEEE regulations. Please consider the effect on the environment when disposing of it. Do not put in a domestic waste bin. Only dispose of at an appointed recycling centre.



RoHS compliant.

This product is designed to meet the requirements of EN50131-2-6:2008
Security grade 2, environmental class II



FC508/* /MULTI/G2/EN Magnetic Flush Contact.

* colour varies

- Flush mounted magnetic contact.
- Four Terminals.
- Double Pole or EOL configuration
- Suitable for domestic and commercial alarm circuits.
- Suitable for double door applications.
- Can be used in installations up to and including grade 2.
- High impact polymer construction.

Operating and Installation Instructions

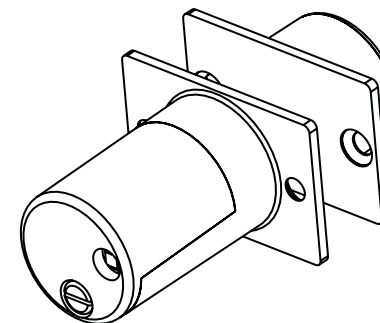

Description

This flush mounted magnetic door contact can be used in most security systems up to and including grade 2 as specified in EN50131-1:2006 and is certified to EN50131-2-6:2008 and environmental class II (for use indoors) by Telefication. It operates as a normally closed circuit going open when the magnet housing is moved away from the contact housing. This contact can be used on most doors to detect the unauthorised entry of an intruder. The contact is protected against tampering by lid removal.

CQR Security, 125, Pasture Road, Moreton, Wirral, CH46 4TH, United Kingdom

Tel: +44 (0) 151 606 9595 Support: +44 (0) 151 606 6311 email: info@cqr.co.uk Web <http://www.cqr.co.uk>

Features

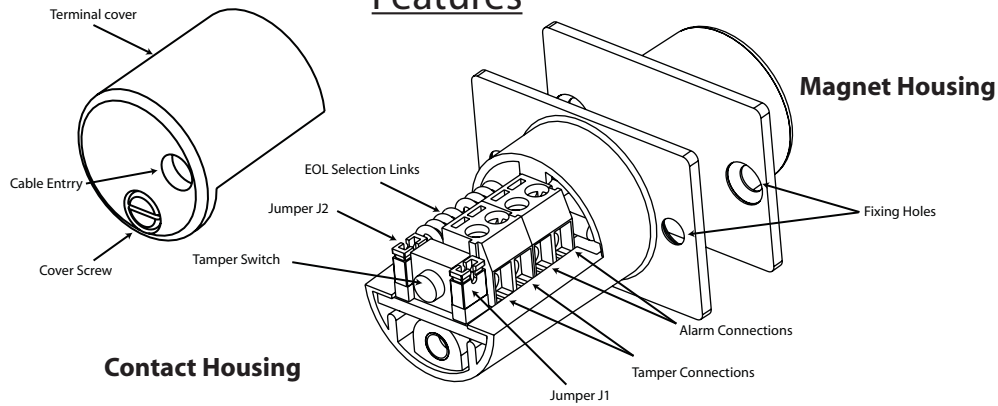

Suitable Applications and Fixing Points

Recommended fixing points ↗
Residential and Commercial Doors

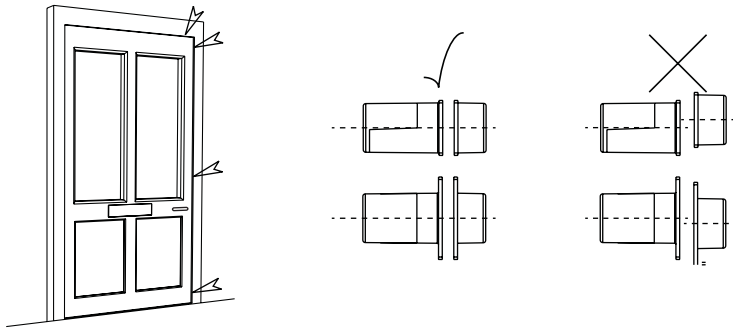

Mounting Instructions

To install the contact housing, drill a 20mm hole into the door frame to a minimum depth of 35mm on the opening side of the door. If the face plate is required to be flush, mark around the face plate and chisel out the wood to the required depth to allow the face plate to be flush with the surface.

Drill a suitable hole at the top of the already drilled 20mm hole to allow for cable entry and feed the cable through it. Remove the cover from the contact and feed the cable through it before terminating the wires referring to the drawings opposite. Refit the cover and insert the completed assembly into the prepared hole and secure with the screws provided. To fit the magnet, carefully mark the position on the door from the already fitted contact to ensure that the centre of the magnet is aligned with the centre of the contact. Drill a 20mm hole to a minimum depth of 15mm into the door, again mark and chisel out the wood if required for a flush fitting with the surface. Place the magnet casing into the hole and secure it using the screws provided.

Wiring Configurations

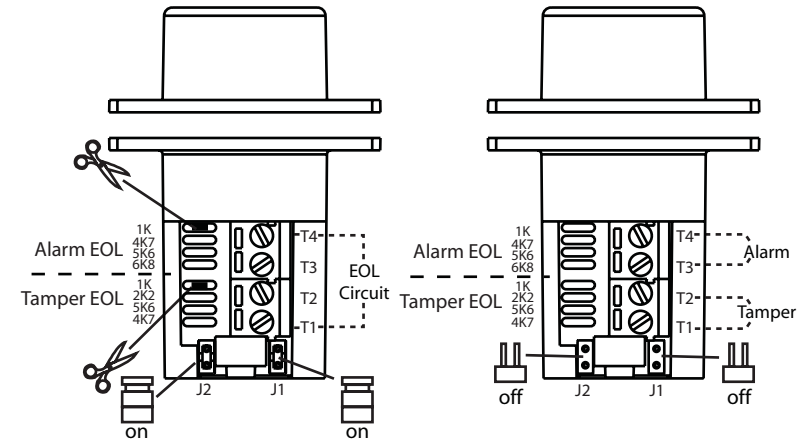

Fully Supervised (Panel type A illustrated)

Leave both jumpers in place.
Cut the appropriate resistor links
(1K 1K illustrated).
EOL Circuit T1 and T4

Double Pole

Remove jumpers J1 and J2
Alarm Circuit T3 and T4
Tamper Circuit T1 and T2

Double Door Fully Supervised Connections. (Panel type B illustrated)

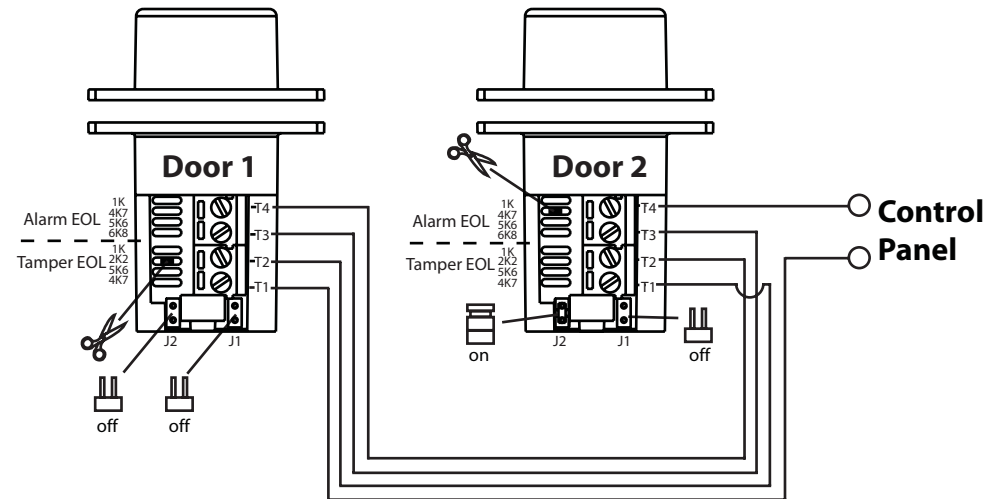

Door 1

Remove jumpers J1 and J2
Cut appropriate tamper resistor link
(2K2 illustrated)
Connect T1 to panel

Interconnections

Connect T2 unit 1 to T1 unit 2
Connect T4 unit 1 to T2 unit 2
Connect T3 unit 1 to T3 unit 2

Door 2

Remove jumper J1 only
Cut the appropriate alarm resistor link
(4K7 illustrated)
Do not cut any tamper resistor links.
Connect T4 to panel