

EN



HOCHIKI OFFICES AROUND THE WORLD

HOCHIKI CORPORATION
E: overseas@hochiki.co.jp
www.hochiki.co.jp

HOCHIKI AMERICA CORPORATION
E: sales@hochiki.com
www.hochiki.com

HOCHIKI MEXICO
E: jbravo@hochiki.com
www.hochikiamerica.com

HOCHIKI EUROPE (UK) LTD
E: info@hochikieurope.com
www.hochikieurope.com

HOCHIKI ITALIA
E: info@hochiki.it
www.hochiki.it

HOCHIKI MIDDLE EAST FZE
E: sales@hochiki.ae
www.hochiki.ae

HOCHIKI EUROPE - INDIA BRANCH OFFICE
E: info@hochiki.in
www.hochiki.in

HOCHIKI (THAILAND) COMPANY LIMITED
E: info@hochiki.co.th
www.hochikiasiapacific.com

HOCHIKI ASIA PACIFIC PTE. LTD.
E: sales@hochikiasiapacific.com
www.hochikiasiapacific.com

HOCHIKI HO CHI MINH REPRESENTATIVE OFFICE
E: sales@hochikiasiapacific.com
www.hochikiasiapacific.com

HOCHIKI CORPORATION - TAIWAN BRANCH OFFICE
E: htr@hochiki.com.tw
www.hochiki.com.tw

HOCHIKI SINGAPORE CORPORATION
E: sales@hochikiasiapacific.com
www.hochikiasiapacific.com

HOCHIKI JAKARTA REPRESENTATIVE OFFICE
E: sales@hochikiasiapacific.com
www.hochikiasiapacific.com

HOCHIKI AUSTRALIA
E: sales@hochikiaustralia.com
www.hochikiaustralia.com



World Class Leaders in Life Safety Since 1918

Hochiki has a distinguished heritage of specialist technological expertise which has gained the group its international status as one of the world's leading manufacturers of commercial and industrial fire detection solutions. Established early in the twentieth century, Hochiki has remained an independent, multi-national company which now employs over 1500 personnel in total, operating five manufacturing plants, thirty-one sales offices and eighteen subsidiaries.

Hochiki Europe (UK) Ltd manufactures and distributes product for Europe, the Middle East, CIS, Indian Sub-Continent and Africa and is dedicated to providing sales and technical services to these markets.

World Proven Performance

With a heritage of innovative design and leading edge technologies, Hochiki's products have gained widespread acceptance as the benchmark for high-integrity and long-term reliability throughout the world.

Research and Development for Life Safety

Hochiki owns the world's largest, purpose-built, state of the art fire test laboratory. This ensures that the pedigree of Hochiki products remains unrivalled and guarantees that even large scale designs are fully proven in real fire conditions.

In addition, the Group employs over 100 specialist research and development engineers that undertake activities from fundamental research into the physical properties of fire, to hardware and software product design and development.

Delivery Quality

Acknowledged globally by system specifiers and integrators as an international market leader in the manufacture of fire products, the main benefits of using Hochiki devices are:

- ▶ High quality of products ensure long term reliability
- ▶ Easy to install
- ▶ Open Protocol for choice and flexibility
- ▶ Reduced cost of ownership
- ▶ Virtual elimination of false alarms
- ▶ Compliance to standards

Types of Fire Detection System

Hochiki offers many types of fire detection system; this includes the ESP intelligent analogue addressable fire alarm system, the CDX conventional system and FIREwave, a hybrid wired/wireless system. These ranges are supplemented by a large selection of ancillary and test equipment.

Product Colour Key

Some products are available in a range of colours, and where appropriate, a colour swatch is shown next to these products denoting which colours are available. For example  denotes product available in ivory.

 Ivory  White  Black  Grey  Red  Blue  Green  Yellow

Marine & SIL Approved

The following icons will be shown throughout this guide to indicate that a product is also available in either a Marine or SIL Approved version. For example the  icon, will tell you that the product is also available in a marine version. If you wish to purchase an alternative version of a particular product please use the product code beside the selected icon.

 Marine Approved  SIL Approved  DIN Variant

Useful Contact Information

Hochiki Asia Pacific

82 Ubi Ave 4

#06-02 Edward Boustead Centre

Singapore

408832

 + 65 6841 9728

 hochiki@hochikiasiapacific.com

 www.hochikiasiapacific.com



Intelligent Fire Alarm Control Panels

Overview	6
Control Panels	8
Repeaters	10
Virtual Resource	12
Configuration Software	14
Network Diagram	16



Intelligent Fire Alarm Control Panels

Control Panels	18
Repeaters	20
Control Marine Control Panels	24
Network Diagram	26



Conventional Fire Alarm Control Panels

Control Panels	28
Network Diagram	30



Conventional Extinguishant Control Panels

Control Panels	32
Network Diagram	38



Power Supplies

Power Supplies	40
----------------	----

ESPIntelligent

Analogue Addressable Fire Detection

Sensors	43
Bases	44
Beams	44
Audio/Visual	45
Modules	47
Manual Call Points	49

CDXconventional

Conventional Fire Detection

Detectors	52
Beam Detectors	54
Bases	54
Audio/Visual	55
Manual Call Points	57



Intrinsically Safe & Explosion Proof

Detectors	60
Bases	60
Manual Call Points	60
Modules	61
Infrared Flame Detection	62

FIREwave

Hybrid Wireless Detection

FIREwave Translator & Expander	64
FIREwave Modules	65
FIREwave Sensors	65
FIREwave Audio/Visual	66

FIRElink

Air Sampling System

FIRElink Detectors	69
FIRElink Accessories	69

ANCILLARY

Equipment

Ancillaries	72
Test Equipment	72
Power Supplies	74
Enclosures	75

BEACON VARIANTS

Guides to our EN54-23 A/A Range

Sounder Beacons	78
Conventional Beacons	79
Ceiling Beacons	80
Wall Beacons	81



The all new L@titude product range of fire alarm control equipment combines the very latest hardware and software to produce a control and indication system, which is powerful and sophisticated, yet simple to use and understand.

www.hochikieurope.com/latitude



L@titude Overview

The all new L@titude product range of fire alarm control equipment combines the very latest hardware and software to produce a control and indication system, which is powerful and sophisticated, yet simple to use and understand.

The flexibility of the L@titude platform is such that it can be re-configured to realise many other control and indication applications, with direct integration into intelligent buildings.

Moving away from the simple, price driven competitive model used by most manufacturers today, the L@titude concept is designed to add value to System Designer, Integrator, Service provider and the end user.

Developed from the “ground up” by Hochiki’s leading design team and using some of the most advanced technology available, L@titude is designed as one of the most powerful, intelligent and technically robust fire alarm products available.

Not only do the products and services offered under the L@titude brand provide solutions to the most technically challenging applications in life safety, L@titude will deliver added value, market advantage and a competitive edge to your business.

The modular nature of the L@titude system allows all field wiring to be connected to a passive mother board enabling addition, re-configuration or replacement of all electronic hardware without the need to disconnect any field wiring.

This modularity also allows each panel to be customised with addressable loop detection circuits, conventional detection circuits, relay cards, additional sounder outputs or programmable I/O modules as required.

Each 2 loop module slot can be fitted with a variety of option boards to provide alternative functionality. These modules include:

- ▶ 8 zone conventional detection board
- ▶ 4 way sounder output board
- ▶ 8 way volt free relay contact board
- ▶ 16 channel programmable I/O board with digital inputs and open collector outputs
- ▶ Media Gateway communications board
- ▶ L@titude “Bridge” Network Card (connect L@titude to your existing HFP network).

By taking advantage of the unique user interface it is possible to further customise the control panel so it can meet specific alternative requirements such as local regional variances, alternative additional functionality or corporate livery.

Although this level of customisation is not generally a user feature, the architecture of the L@titude control system makes customisation almost limitless.



L@titude Analogue Addressable
2-16 Loop Control Panel



Selection of I/O Boards



VR L@titude Media Gateway

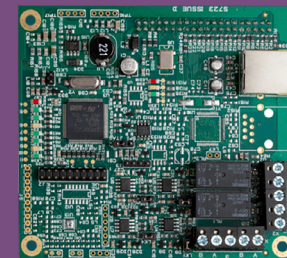

L@titude Network Card



L@titude 2-16 Loop Control Panel



Analogue Addressable 2-16 Loop Control Panel

With the increasing demands for power in fire detection and alarm systems, L@titude Fire control panels are well placed to meet current and future needs.

All panels are available with either a 5.25A, 24V power supply capable of charging up to 26Ah batteries or a 10.25A, 24V power supply capable of charging up to 45Ah batteries. L@titude Fire Panels can be supplied with a range of remote power supply units making the control panel smaller and easier to install.

Up to 500 milliamps is available for each detection loop allowing for a generous quantity of loop powered devices.

The four sounder circuits are each capable of supplying up to 2.5A at 24V to audio and audio visual devices (PSU dependant).

The addition of a L@titude Media Gateway communications device configured to report to the Virtual Resource servers and subscription to one or more Virtual Resource browser based software modules, allows systems to be managed remotely and from any location in a simple and efficient manner.

L@titude Media Gateway also provides the interface between control systems and other products and utilities such as PC graphics, Voyage State Recorder and a growing number of third party L@titude compatible products.

Configurable serial ports will allow connection to BMS systems using LonWorks, Modbus or BACnet protocols.

L@titude fire systems are scalable with L@titude Net Enhances High Speed Networking. This allows up to 127 panels to be connected together as a fully fault tolerant networked system with rapid inter panel communications and up to 1.2km of standard two core fire resistant cabling between nodes.

Each panel can be configured to display all or any events from any other panel allowing master/slave, multiple master/slave or peer to peer configuration.

Sophisticated network analysis tools provide the ability to identify connection problems instantly and the commissioning mode allows individual panels to be prevented from transmitting events to the network while maintaining communications.

Adding a L@titude “Bridge” Network Card to your L@titude Panel or L@titude Network provides an interface between existing HFP and L@titude Control System providing backward compatibility and a unique upgrade path.

Features

- ▶ Compliant with EN54-2, EN54-4, EN54-13
- ▶ 2 to 8 loop or 2 to 16 loop versions
- ▶ 500mA loop current
- ▶ 4 programmable sounder circuits each rated at 2.5 A
- ▶ 5.25 A or 10.25 A, power supply options
- ▶ 3 programmable inputs
- ▶ 5 programmable relay outputs
- ▶ Hard wired fire and fault routing inputs and outputs
- ▶ Modular electronics
- ▶ Over 4000 sub address points per panel
- ▶ Option to “invert” inputs and outputs
- ▶ Powerful, standard configuration templates
- ▶ Network up to 127 panels
- ▶ Configurable via USB port to PC or memory stick
- ▶ 2 ancillary serial ports
- ▶ Up to 512 programme Input/ Output via optional u plug in and serially connected expansion cards.



L@titude Intelligent Repeater

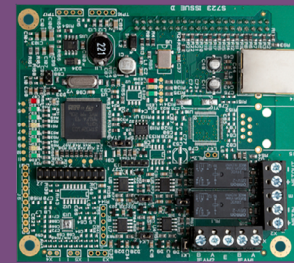

L@titude Network Card



Multi Purpose Flushing Collar

L@titude

Intelligent Repeaters

L@titude provides a means of allowing full display and optional control of the L@titude fire alarm control panel from a small and unobtrusive local control station.

Based on an all new hardware and software platform, the large, full colour graphical display with touch screen functionality, delivers information on the status of the fire alarm system to single or multiple locations.

L@titude repeaters can be configured to offer full display and control to replicate the functionality of the fire control panel or to operate as a simple, display only device for applications where access to control the fire alarm system would be inappropriate.

For other annunciation and control applications, L@titude can be configured to provide customisable switches and indications for a host of fire system ancillary functions.

L@titude repeaters may be connected to the fire control panels' fault tolerant network using fire rated cable offering flexibility in system wiring.

Available in several standard formats, L@titude can be mounted directly onto a wall, be recessed using our quick-fix adaptor frame or fully flush mounted. Special enclosure finish and colours are also available to match existing decor.

Features

- ▶ Robust, full colour, 7" 800 x 480 touch screen graphical display
- ▶ Full indication of all information displayed at the fire control panel
- ▶ Automatic display brightness adjustment
- ▶ (Silenceable) internal sounder
- ▶ Connections Via:
 - ▶ Option to connect to control panel network
- ▶ Low current, 24 VDC powered
- ▶ Slim compact construction
- ▶ Configurable functionality
- ▶ Configurable languages
- ▶ Optional Enable Key-switch.



@titude Virtual Resource

A Comprehensive Suite of Software Based Tools

To compliment the new, market leading range of control systems. Virtual Resource is a unique suite of software tools aimed to deliver a whole new dimension in Life Safety System Management. It provides System Designers Integrators and Service Companies with the ability to remotely access and comprehensively manage any system using intelligent analysis of data collected from those systems. End-users and facilities managers can also greatly benefit from the powerful feature set that comes with Virtual Resource. Virtual Resource is one of the most technically advanced management tools for fire detection and other safety systems on the market. With Virtual Resource, installers and service providers are able to offer market leading functionality through remote management and provide improved service at lower cost and greater efficiency. The remote management features offered by Virtual Resource can result in reduced fault call outs, improved servicing regimes, more effective maintenance, reduction of unwanted alarms and improved overall service to the end user.

Access

Gain access to data from all of your systems, assess performance, check status and make decisions based on facts, not assumptions. VR Access allows a Virtual Resource enabled fire system to periodically report its status to the secure servers and allows a VR Access subscriber to view the latest status report via any web enable device.

Vault

Subscribers to Virtual Resource can securely store system and site related documentation on our permanently backed up servers using VR Vault. VR Vault provides a convenient and permanently accessible storage location for all documentation related to an installation including installation drawings, commissioning details and certificates, service and maintenance records, general notes and any other documents related to the installed system that the user requires.

Services

VR Service provides a means to set up a comprehensive fire alarm system servicing regime adding benefit to both the end customer and Service company. Site details can be imported from VR Access or added and set up manually to create customer records. Service frequency and device activation list schedules can be set and resources allocated including travelling time and estimated time to complete the service providing essential data for planning service engineer 's activities. Service engineers can view and print their work schedules including site specific notes and previous service records directly from the system if required.

Print

Designed to replace panel mounted printers which provide very limited information. VR Print provides a secure method of storing and recalling the control system. The user can simply view the systems events online, print PDF reports or download the data.

Features

- ▶ Unique Life Safety management utility
- ▶ Remote access to system data from anywhere
- ▶ Revenue driver for all business sizes
- ▶ Cut costs and rise up productivity
- ▶ Reduce environmental impact through technology
- ▶ Modular application based tool set:
 - ▶ VR Access: View and manage my projects
 - ▶ VR Vault: Store and retrieve system documentation
 - ▶ VR Service: Manage, add value and Improve compliance
 - ▶ VR Print: Virtual Printer
- ▶ More to come...
More VR applications will be added to the list providing users with further enhancement to their value and revenue streams.

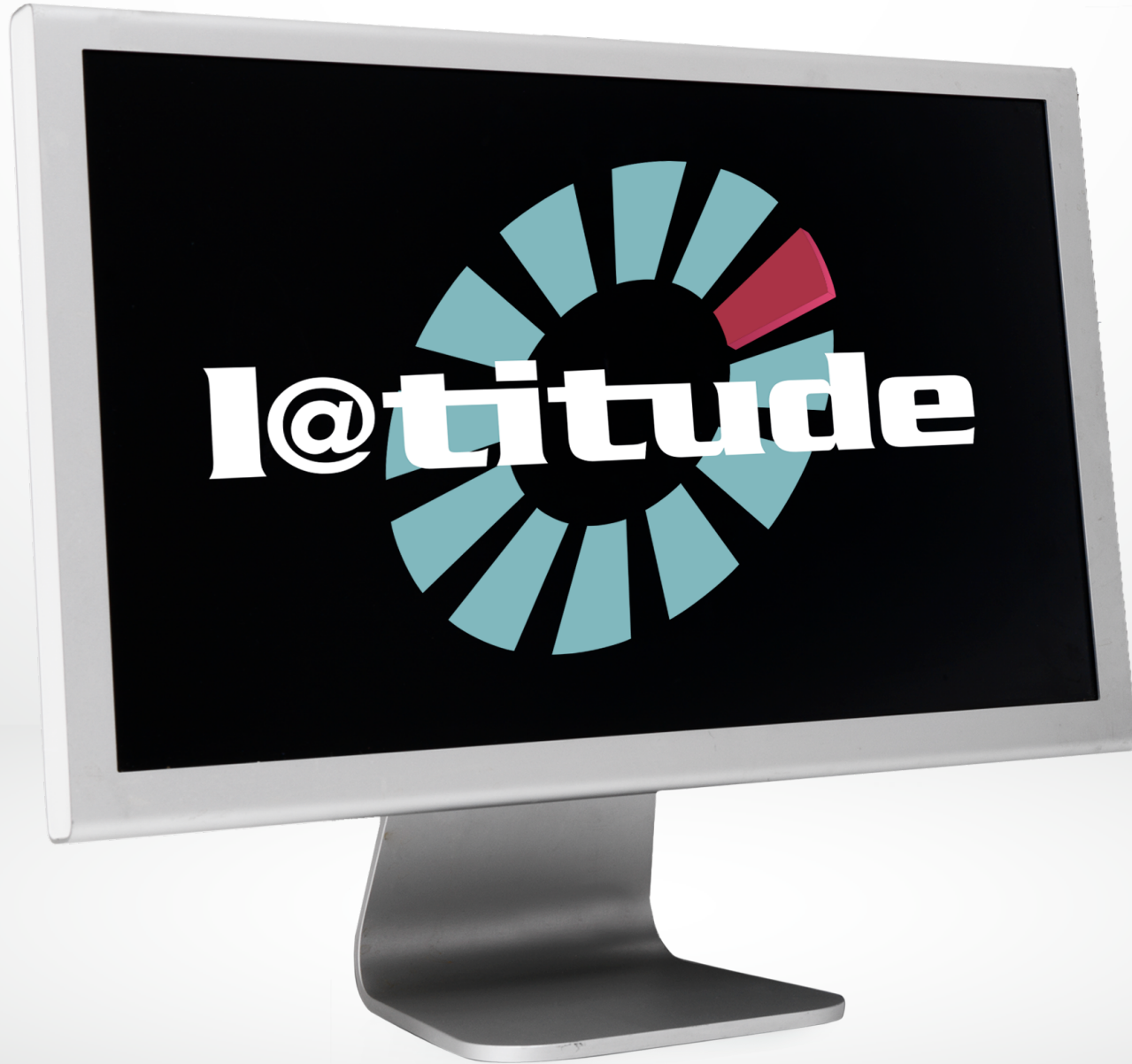

L@titude Configure

Loop Explorer 2 (LE2) Configuration Software

To compliment the new, market leading range of control systems. Virtual Resource is The powerful central processor and extensive on board expandable memory in the L@titude Fire control system, allows demanding configuration options and many thousand of cause and effects to be processed quickly and efficiently.

Logical operators such as COINCIDENCE, AND, OR, NOT, TIME OF DAY and INTERVAL TIME along with the ability to group inputs and outputs into collections other than zones and the capability to configure up to 2000 zones produces a system capable of fulfilling in the most demanding of control applications.

A standard USB port allows configurations stored on a USB memory stick to be loaded to the control panel without the use of a PC.

The HFP Loop Explorer 2, PC configuration software provides a familiar, simple to use PC application with the power to produce the most complex configurations via an easy to use and intuitive interface.

Maintain the look and feel of the industry leading original HFP Loop Explorer 1 configuration utility, HFP Loop Explorer 2 is itself highly configurable allowing customisation of languages, colour schemes and company logos and allowing exposure to single or multiple detector protocols to be set for each user.

Additional logical operations for NOT and TIME functions for use in cause and effects and the inclusion of “groups” (collections of devices not necessarily in the same zone) increase the power and flexibility of HFP Loop Explorer 2 to far beyond what was achievable with its forerunner and most other products currently on the market.

Powerful standard templates allow rapid configuration of common fire system configurations for applications such as high rise buildings or alarm verification from hotel rooms.

Cause and effect processing power is now practically limitless allowing the configuration of large, complex networks with ease. Access to HFP Loop Explorer 2 is via a secure web server, so users with the appropriate credentials have permanent access to the latest version ensuring that the most recent enhancements are always available. HFP Loop Explorer 2 can be customised by the user so that language or specific terminology can be set as defaults for all systems that are configured using HFP Loop Explorer 2. Custom changes are stored on our servers, once more ensuring that all authorised users have access to the latest customised versions.

For added convenience, L@titude Virtual Resource subscribers can store HFP Loop Explorer 2 configuration files on our secure servers ensuring that the site configuration is always backed up and available to users with the appropriate access rights.

Features

- ▶ Based on the industry leading HFP Loop Explorer
- ▶ Delivered and managed via the new L@titude.com website
- ▶ No more out of date version in circulation
- ▶ Many new features and benefits
 - ▶ Time Manager
 - ▶ Group Manager
- ▶ Up to 5000 Cause and Effect options
- ▶ Additional C & E operators
- ▶ “Not” and Time
- ▶ Powerful templates
- ▶ Favourite device tab
- ▶ Language support.



L@ti-View

Powerful and Sophisticated Software Solution

No situation requires a more urgent response than a fire event. On a large public site, especially during busy periods, public safety is paramount.

A powerful and sophisticated software solution, L@ti-View gives building managers complete monitoring and control over fire detection, providing a comprehensive fire risk and incident management system. Where time is of the essence, site managers can respond quickly and efficiently to a fire event. L@ti-View plays a crucial role in safeguarding people, vitally important information and property.

Visual Fire Management

L@ti-View can automatically switch to the area on the site map to where a fire device has been activated to quickly view an event and begin immediate investigation. In addition, it will show the relevant muster and fire control points.

It also provides a full capability to monitor a Fire Alarm System for faults and alarms and allows the operator to easily manage a fire incident.

Immediate Response

With L@ti-View, operators and users are alerted to an event as soon as it occurs and are directed to the location of the event.

Fire System Maintenance

A maintainer's area provides dedicated functions for a fire alarm system's maintenance team. A comprehensive list of all fire devices along with their statuses, cause and effect rules and integration settings allows operators to quickly view a device, make changes and disable devices all from one workstation.

For all fire devices on the site, a maintainer's log shows operators and engineers a view of all recorded maintenance activities, previous faults and status histories to help speed up maintenance procedures and device checks.

Flexibility

L@ti-View enables permissions to be given to users. There are four default user accounts configured upon installation. Additional accounts can be created by the administrator.

These user accounts use default permissions groups, but user accounts and groups can be cloned and edited to suit site requirements.

Features

- ▶ Supports dual screens, allowing a dedicated screen for the 2D location images and a separate screen for listing active events and system management.
- ▶ Fully configurable on site using administrator login.
- ▶ Reports configuration mismatch errors – ensuring that the graphics system is properly maintained and updated whenever there are any panel configuration revisions.
- ▶ Powerful event log filtering and reporting.
- ▶ Manage the state of the fire system using a combination of graphical images and system controls.
- ▶ Programmable macro buttons to perform panel control operations.
- ▶ Full map navigation using configurable buttons or map areas.
- ▶ Device analogue value reporting.
- ▶ Perform device and zone disablements/enabements.

L@titude Connectivity

Initial Setup and Expandability

L@titude Addressable Control Panel
2 - 8 Loop / 2 - 16 Loop



Comes as standard with:

1 Loop Card
(2 Loops per card)



With space for up to 4 Loop Cards
(each card provides 2 Loops)



Network Card allows 32
L@titude Repeaters/Panels to
be added to the network.



Media Gateway card allows connection
to VR Nimbus, Vizulinx and L@ti-view^{*2}

Each loop is capable
of hosting upto
127^{*1} addresses

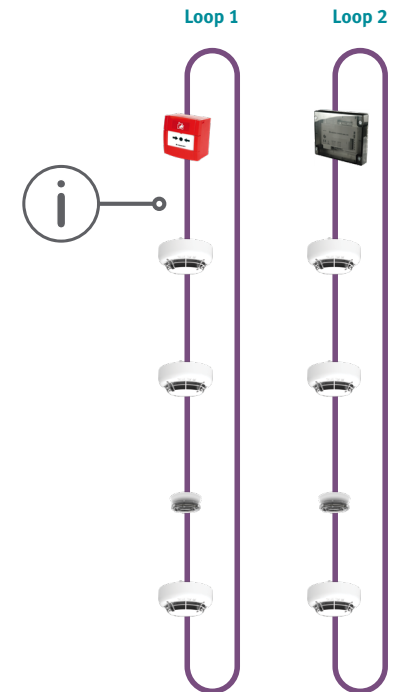

^{*1}Future updates planned ^{*2}BMS systems using LonWorks, Modbus or BACnet protocols coming soon.

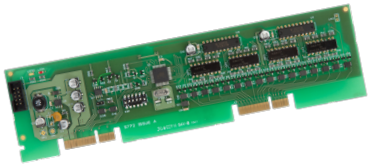

16 Channel I/O Board

To add more I/O capability to the @titude control panel

- ▶ 16 channels
- ▶ Each channel configurable as input or output
- ▶ Inputs opto-isolated
- ▶ Outputs open collector transistor
- ▶ Simple 2 wire connection to control panel
- ▶ Up to 32 boards supported per panel (512 Input/Output Channels)
- ▶ Inputs and outputs configurable as per field devices
- ▶ Full cause and effects on all inputs and outputs
- ▶ Multi drop RS485 communications
- ▶ Can be used with other HFP I/O modules on the same panel
- ▶ Compatible with HFP AS panels.



8 Way Relay Extender Board

Additional relay output capability can be added using HFP relay boards.

- ▶ 8 volt free changeover relay contacts (1AMP 30V DC)
- ▶ Relay operated indications
- ▶ Remote connection to panel via RS485 serial bus
- ▶ Common footprint to other HFP I/O board types
- ▶ All outputs programmable for cause and effects
- ▶ Can be used with other HFP I/O modules on the same panel
- ▶ Compatible with HFP AS panels.

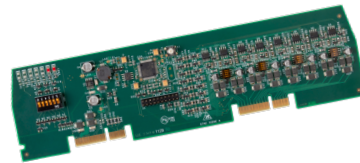

8 Way Conventional Detection Zone Board

Four conventional detection circuits can be connected with up to 30 detectors per circuit.

- ▶ 4 monitored detection zone inputs
- ▶ 2 monitored sounder outputs
- ▶ Volt free fire contact
- ▶ Volt free fault contact
- ▶ Local power supply fault input
- ▶ RS485 comms connection to HFP Fire Alarm Panel
- ▶ Individual fault and operated indications for inputs and outputs
- ▶ Directly replaces a conventional control panel when integrating into an analogue addressable system
- ▶ Can be used with other HFP I/O modules on the same panel
- ▶ Compatible with HFP AS panels.

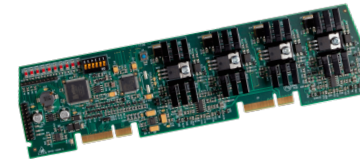

4 Way Sounder Extender Board

Additional sounder output capability can be added using HFP sounder boards.

- ▶ 6 individually fused and monitored sounder outputs
- ▶ Fault and operated indications
- ▶ 2 opto-isolated general purpose inputs
- ▶ 2 volt free contact general purpose outputs
- ▶ Remote connection to panel via RS485 serial bus
- ▶ Common footprint to other HFP I/O board types
- ▶ All outputs and inputs programmable for cause and effects
- ▶ Can be used with other HFP I/O modules on the same panel
- ▶ Compatible with HFP AS panels.

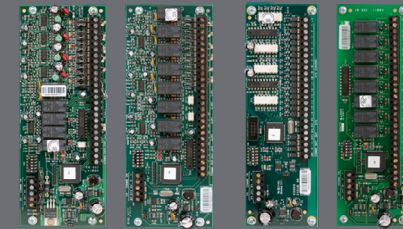

Selection of I/O boards

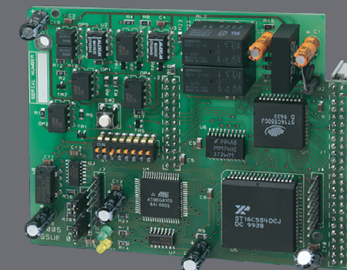

HFP Network Card

HFP AP-AS

Analogue Addressable 1-2 Loop Control Panels

The HFP AP-AS is a powerful and versatile Single or Two Loop Analogue Addressable Fire Control Panel.

HFP AP-AS supports Hochiki ESP loop drivers, which are all capable of providing up to 400 milliamps of loop current for the most demanding applications.

An integral 3 Amp power supply and temperature compensated battery charger provides ample power for the two, 1 Amp rated standard sounder outputs, loop powered sounders and other devices.

HFP AP-AS is also available as a HFP AP-ASL version offering a very cost effective solution for smaller standalone installations requiring only one detection loop.

THE HFP AP-ASL version does not support the following: Second loop, Printer output, Networking and connection of I/O boards or the HFP AP-CRL repeater.

Connectivity

HFP AP-AS connects seamlessly to other HFP AS, or HFP multi loop panels and repeaters via the fully fault tolerant and robust HFP network. The HFP AP-AS supports all HFP serial bus peripherals such as HFP AP-CRL repeaters, 16 channel I/O boards, Relay boards, Sounder boards and Conventional Zone boards to provide an additional 512, fully programmable points. 16 zonal LED indicators are provided as standard and the panel will support up to 500 network wide software zone as per HFP multi loop panels.

Software

Programming, including powerful cause and effect functionality can be achieved using the intuitive HFP loop Explorer configuration utility familiar to HFP panels users. The new HFP Loop Explorer 2 will also support all of the HFP AP product family.

The Guide graphics system or a modem for remote3 system interrogation by telephone lines may also be connected to HFP AS Panels via the RS232 serial connection.

Installation

The elegant and simple construction of the panel enables the chassis to be completely dismantled by removing just two screws. The outer cover can also be detached by removing two hinge pins making first fix installation very simple and enabling the sensitive electronic parts to be stored safely for re-fitting at the commissioning stage.

Housed in the same installer-friendly and attractively styled enclosure as the popular HFP CP (Conventional) and HFP CP-XT (Extinguishant) range of fire control panels, HFP AP-AS combines compact and practical styling with the programming power and connectivity normally associated with much larger systems.

Features

- ▶ 16 zonal LED indicators
- ▶ 2 programmable sounder circuits
- ▶ 3 programmable relays
- ▶ 3A power supply
- ▶ Large graphic display
- ▶ Expandable from 1 to 2 loops*
- ▶ Certified to EN54-2/ EN54-4
- ▶ Up to 512 additional programmable I/O via HFP I/O modules*
- ▶ Stores 500 last events in event log
- ▶ Dial up modem connection available
- ▶ Compact, stylish enclosure
- ▶ Different language and character set variants available
- ▶ Real time clock
- ▶ 5 programmable inputs
- ▶ Installer friendly, removable equipment chassis
- ▶ Sensitivity adjustment and Drift Compensation
- ▶ Compatible with HFP and HFP AP-CRL repeaters*
- ▶ Can be networked with HFP - control panels *
- ▶ Fully EN54-2 and EN54-4 compliant improved front loading Printer option* **
- ▶ Powerful, network wide cause & effects*

*These items not available on HFP ASL panel. ** Can be fitted to M3 size enclosure only



HFP AP-CRLS

HFP Repeater

Analogue Addressable Fire Control Panel Repeater

HFP AP-CRLS

Local LCD Control Repeater

The HFP AP-CRLS fire alarm repeater provides an alternative to HFP AP-PRNS network connected repeaters and provides a cost effective, simple and convenient method of extending the controls and indications of the HFP fire alarm control panel to other locations.

The larger, graphic LCD, brightness LED indicators and full set of controls duplicate the indications and controls on the HFP fire alarm control panel at up to 15 additional locations via a (separate to the HFP network) simple, two wire serial data connection.

Ideal for locations where a control and indication point smaller than a full fire alarm control panel is required the HFP AP-CRLS is available in either a 24 VDC powered option (which can be powered via an additional 2 cores from the HFP control panel auxiliary 24 VDC supply) or a 230V power option with local battery back up.

Peripherals

HFP AP-CRLS Local LCD Control Repeater

- ▶ Semi-Flush Mounting
- ▶ Power Supply 750mA
- ▶ Access Enable Key-switch

For our full list of Panels download your HFP Price list from www.hochikieurope.com



W: 385mm x H:310mm x D:90mm



W: 500mm x H:355mm x D:117mm



W: 385mm x H:520mm x D:110mm



W: 500mm x H:650mm x D:137mm

HFP AP-MATRIX

Intelligent Fire Alarm Mimic Display System

HFP Matrix

The HFP Multi Loop Analogue Addressable fire Control Panel range offers a powerful and scalable solutions for fire detection and alarm systems.

With proven and mature software at its heart, the HFP range benefits from many years of development and refinement to provide a fire alarm control panel range of outstanding robustness, versatility and flexibility.

HFP multi-loop fire panels have a large clear display, context sensitive help screens, easy navigation menus, versatile configuration options and simple control all enhanced by the power and flexibility that comes from compatibility with other components of the multi-loop HFP system and peripherals.

HFP fire panels fully support Hochiki ESP loop drivers, which are capable of providing up to 400 milliamps of loop current for the most demanding applications.

An integral 5.25 Amp power supply and temperature compensated battery charger provides ample power for the 4 standard sounder outputs, loop powered sounders and fully loaded loops of devices.

Connectivity

HFP fire panels connect seamlessly to HFP AS fire panels or other HFP multi-loop panels and repeaters via the fully fault tolerant and robust HFP network. The network topology can be configured for either a fully secure “loop” or as an “open ended” network for replacing older systems and using existing cabling.

The HFP range supports a selection of serial bus peripherals such as HFP AP-CRL repeaters, 16 channel I/O boards, Relay boards, sounder boards and Conventional Zone boards to provide an additional 512, fully programmable points. 0, 16, 48 or 96 zonal LED indicators can be provided as standard and the panel will support up to 500 network wide software zones.

Software

The long established HFP Loop Explorer configuration utility can be used to configure the HFP range. With the all new HFP Loop Explorer 2 offering a simpler and more intuitive programming configuration tool capable of realising the largest and most complex fire alarm systems with ease.

The Guide graphics system or a modem for remote system interrogation by telephone lines may also be connected to HFP panels via the RS232 serial connection. All of the above produce an outstanding and competitive, world class fire alarm control panels range.

Installation

The elegant and simple construction of the HFP panel range with full mechanical protection of all internal electronics, ensures ease of installation and protection of the vital parts during installation.

Features

- ▶ Up to 504 LEDs can be controlled from any HFP AP-S or HFP AP-AS panel (except HFP AP-ASL)
- ▶ Full colour printing
- ▶ Available in a range of standard enclosures to suit any applications
- ▶ Bespoke sized units can be made upon request
- ▶ Choice of Red, Green or Yellow LEDs
- ▶ Available with or without controls
- ▶ Same look and feel as HFP range
- ▶ HFP Matrix can easily be upgraded on site with minimal cost and effort
- ▶ EN54-4 approved PSU (optional)
- ▶ Configured via standard HFP Loop Explorer Software



Detectors & Devices

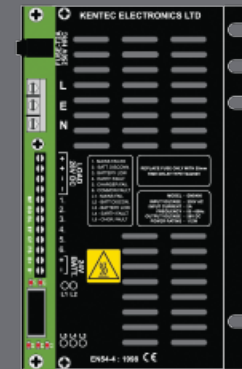

Marine Repeater

MARINE ASM

Marine & Offshore Analogue Addressable 1-2 Loop Control Panel

Based upon the popular HFP single and two loop analogue addressable fire control panel, the MARINE-ASM is certified with a host of classification societies and is Marine Equipment Directive approved.

MARINE-ASM provides a cost effective and scalable solution for all marine fire alarm systems.

Up to 64 MARINE-ASM control panels may be networked to provide integrated control and indication of over 16000 fire alarm points.

The optional Voyage Data Recorder interface outputs standard NMEA 0183 protocol and can be fitted inside any control panel on the network.

Suitable for all small to medium sized vessels, MARINE-ASM control panels can be expanded and networked to become part of much larger networks

With its large graphical display and ergonomic buttons and indicator layout, the MARINE-ASM control panel is simple and straight forward to understand for installers, commissioning engineers and end users alike

Features

- ▶ 16 zonal LED indicators
- ▶ 2 programmable sounder circuits
- ▶ 5 programmable inputs
- ▶ 3 programmable relays
- ▶ 3A power supply
- ▶ Large graphic display
- ▶ Real time clock
- ▶ Powerful, network wide cause and effects
- ▶ Sensitivity adjustment and Drift Compensation
- ▶ Hochiki protocol
- ▶ Same look and feel as HFP range
- ▶ Stores 1000 last events in event log
- ▶ Compact, stylish enclosure
- ▶ Installer friendly, removable equipment chassis
- ▶ Different language and character set variants available
- ▶ Fully EN54-2 and EN54-4 compliant

HFP Network Diagram

High Integrity Configurable Network

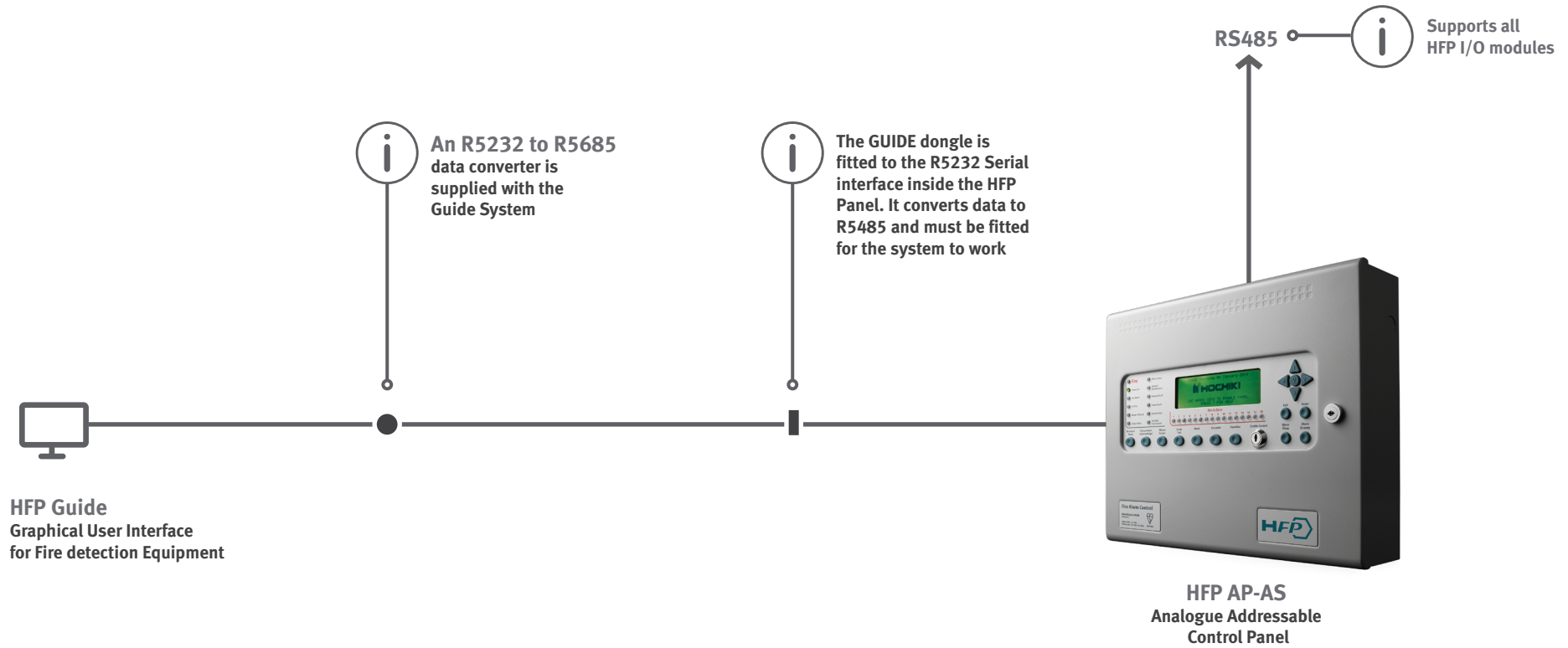

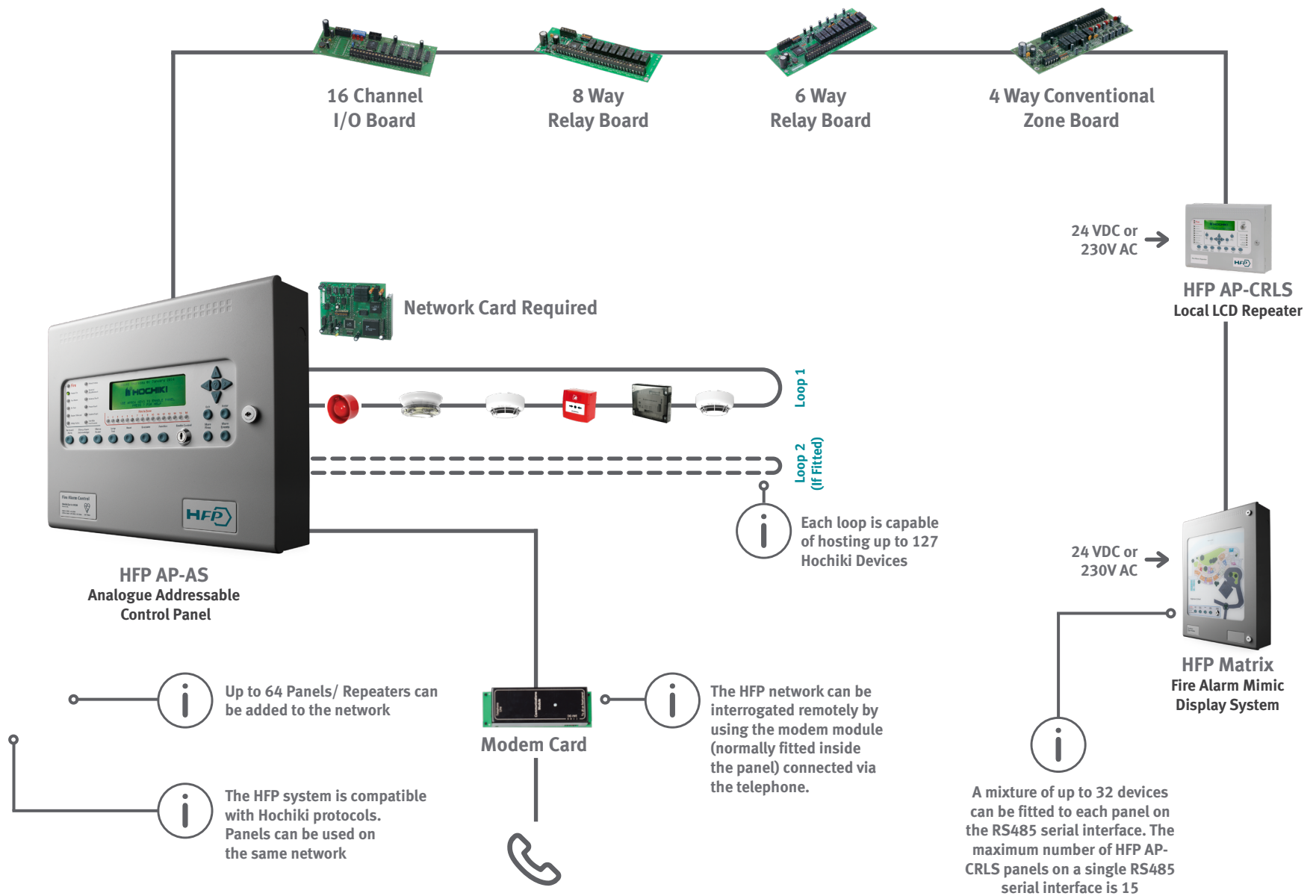



HFP CP-R Repeater Panel

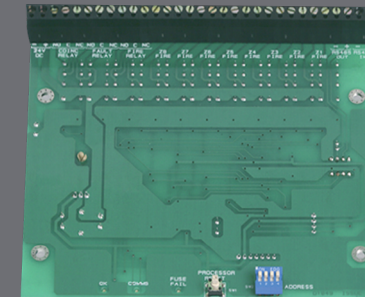

HFP CP Ancillary



Sounder Controller Units

HFP CP

Conventional Fire Alarm Control Panel

The HFP CP range of conventional fire control panels are high specification, fully featured control units designed for the most demanding of conventional fire detection and alarm system applications.

HFP CP is available with two, four or eight detection zones in standard or installation saving, “two wire” versions. The extensive range of configuration features available ensure suitability for new installations or panel replacements on older systems.

Configuration options are stored in non volatile memory and are easily accessed via an intuitive user interface which allows the configuration data to be viewed and changed simply and easily.

HFP CP control panels are compatible with most standard, conventional detectors, call points and sounders and are also compatible with “two wire” detector bases from Hochiki.

An integral three Amp power supply and temperature compensated battery charger provides ample power for the two, 0.5Amp rated standard sounder outputs, zonal sounder outputs on “two wire” versions and an auxiliary 24V supply output.

Powerful Features

The simple and intuitive programming interface on HFP CP panels allows simple configuration of many parameters by entering simple codes which are listed on the inner door look up table and in the operation and maintenance manual. Configurable options include sounder delays, short circuit triggering of zones, non latching zones, silent zones, I.S. barrier compatible zones and system disablements.

Connectivity

HFP CP control panels have a dedicated; serial bus for connection of repeater panels, Ancillary relay boards or zonal sounder extension boards. Up to seven units may be connected to the serial bus which can be up to 1200 metres in length. All units connected to the serial bus are fully monitored and the control panel will announce a fault condition showing the address and type of any units that fail or are disconnected after the panel has been configured to recognize them.

“Two wire” versions of HFP CP can have detectors, call points and standard, polarized sounders connected to the same two core cable, greatly reducing installation time and cost on some installations.

These “two wire” versions also provide the capability of zonal sounders which may be configured as zonal alarm (sounders operate only in the zone of activation), common alarm (all sounders in all zones operate) or two-stage alarm (sounders are continuous in the zone of activation and pulsing in all other zones).

Installation

The elegant and simple construction of the panel enables the chassis to be completely dismantled by removing just two screws. The outer cover can also be detached by removing two hinge pins making first fix installation very simple and enabling the sensitive electronic parts to be stored safely for re-fitting at the commissioning stage.

Housed in the same installer-friendly and attractively styled enclosure as the popular HFP CP (Conventional) and HFP CP-XT (Extinguishant) range of fire control panels, HFP AP-AS combines compact and practical styling with the programming power and connectivity normally associated with much larger systems.

Features

- ▶ Fully certified to BS EN54-2 and BS EN54-4
- ▶ 2-wire and standard versions in 2, 4 or 8 zones
- ▶ Compatible for use on BS5839: Part 1: 2013 installations
- ▶ 2-wire repeaters and ancillary boards
- ▶ Simple, single board construction
- ▶ Installer friendly
- ▶ Compatible with wide range of detection devices
- ▶ Two monitored sounder outputs
- ▶ 3 Amp power supply
- ▶ Auxiliary power output
- ▶ Fully programmable using simple menu options
 - ▶ Adjustable sounder delay time
 - ▶ Sounder configuration options
 - ▶ Silent zones
 - ▶ Zone input delay
 - ▶ Coincidence input selection
 - ▶ I.S. Barrier selection by zone
 - ▶ Short circuit fire by zone
 - ▶ Non latching zones
 - ▶ General panel configuration
 - ▶ Zonal sounder delay call detectors only
 - ▶ Zonal sounder delay call points only

HFCP Network Diagram

High Integrity Configurable Network

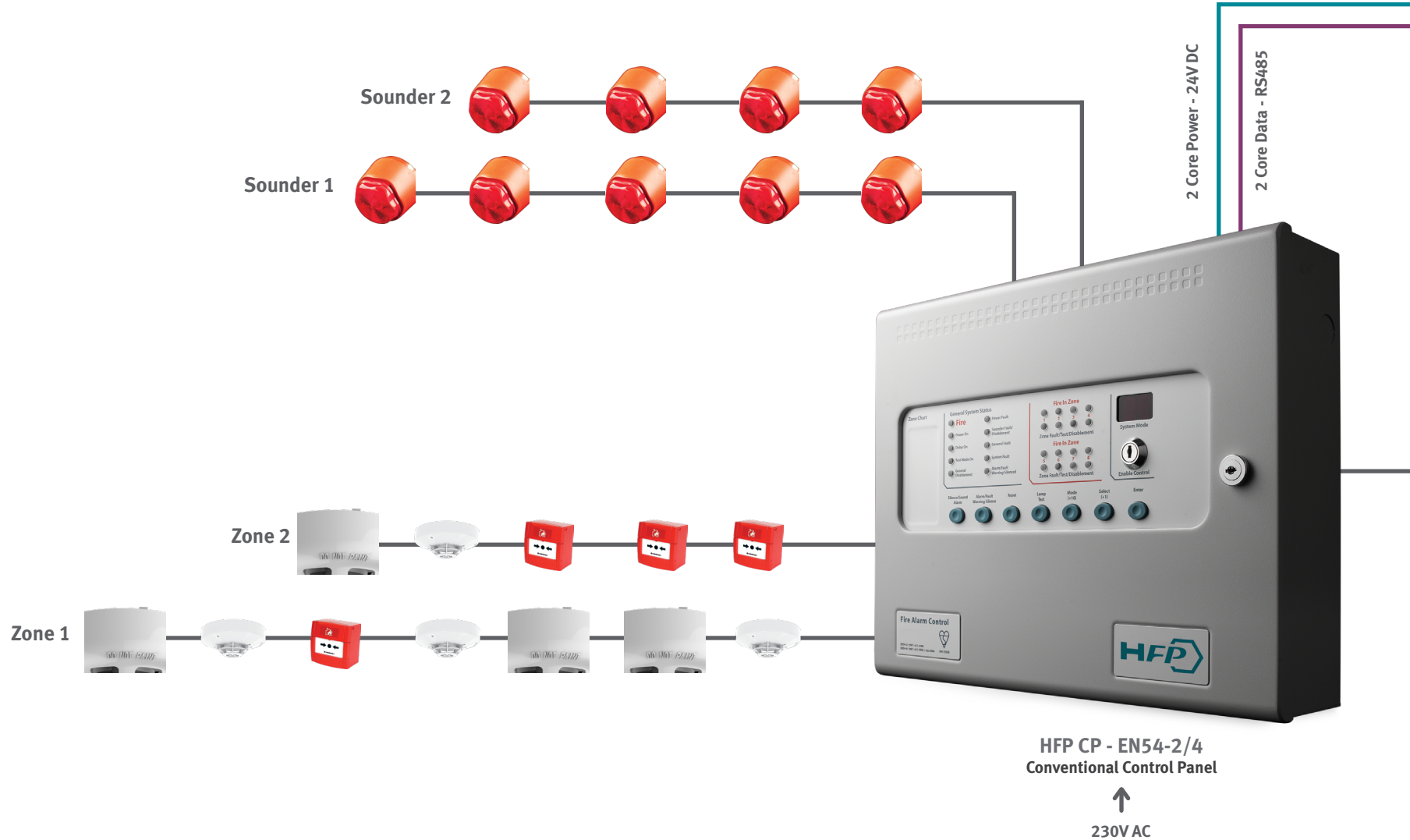

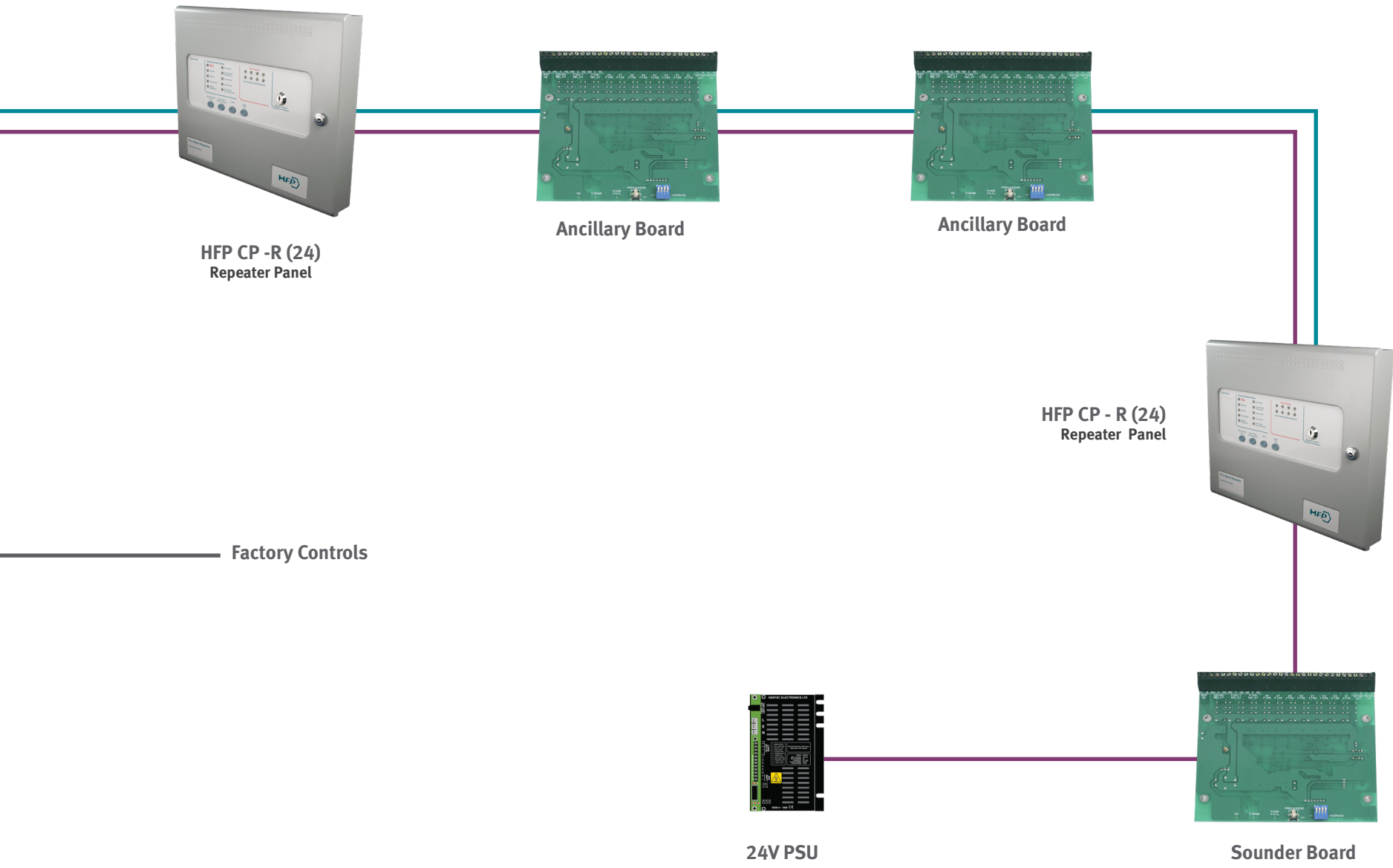



HFP CP-XT



HFP CP-XT Status Units



HFP CP-XT Hold Off Switch

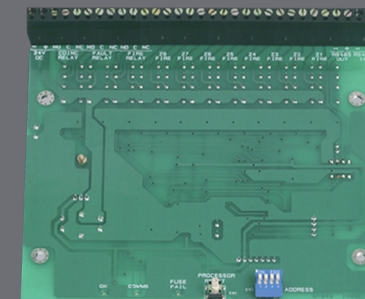

HFP CP-XT Ancillary PCB

HFP CP-XT

Extinguishant Control Panel

Designed and manufactured to the highest standards in a quality controlled environment, the HFP CP-XT extinguishant releasing panel offers outstanding value and performance for all small to medium fixed fire fighting installations.

With three detection zones as standard, extinguishant release can be configured to activate from any combination of detection zone inputs to allow (among other combinations) any two from three type activations such as would be required for detection in ceiling void, room and floor void applications.

The extensive configuration options of the HFP CP-XT allow the functionality of the system to be extensively modified while still complying with the requirements of the controlling standards for the equipment.

The panel contains a large LED display to enable easy configuration and control which also displays the time remaining until extinguishant release for added user safety.

The countdown timer is duplicated on up to seven remote status units to provide local indication of the extinguishant system status. With all of the electronics mounted on a single, easily removable, steel plate HFP XT panels are both robust and easy to install.

Connectivity

To compliment the HFP CP-XT control panel there is a range of system status units.

Up to seven status units can be connected on a serial bus and require just two cores for data and two cores for power. Once connected, status units are supervised and the HFP CP-XT control panel will indicate a fault condition should any unit become disconnected.

Installation

The elegant and simple construction of the panel enables the chassis to be completely dismantled by removing just two screws. The outer cover can also be detached by removing two hinge pins making first fix installation very simple and enabling the sensitive electronic parts to be stored safely for re-fitting at the commissioning stage.

Features

- ▶ Approved to EN12094-1, EN54-2 and EN54-4
- ▶ Three detection zones as standard
- ▶ Any single zone or any combinations of zones can be configured to release
- ▶ Configurable first stage sounder delays
- ▶ Configurable detection delays
- ▶ Zero time delay upon manual release option
- ▶ Compatible with I.S. barriers
- ▶ Configurable extinguishant delays up to 60 seconds in 5 second steps
- ▶ Configurable extinguishant duration up to 5 minutes in 5 seconds steps
- ▶ Countdown timer shows time remaining until release
- ▶ Supports up to seven, four wire status indicators
- ▶ Built in Extract Fan control
- ▶ Non-latching zone input option to receive signals from other systems such as aspirating equipment



HFP CP-XT+

HFP CP-XT+

Extinguishant Control Panel Multi-Area

The HFP CP-XT+ range combines feature rich, HFP CP conventional fire detection from two to eight zones with highly configurable extinguishing control modules to provide an integrated control solution for extinguishing systems with up to four protected areas.

The fire detection section connects to the extinguishant control modules via a serial link which allows secure, bi-directional transfer of data between the two. HFP CP-XT+ modules may be mounted remotely in separate enclosures and connected to HFP CP panels via this serial interface to provide central fire detection and control with distributed extinguishing systems.

HFP CP-XT+ modules may also be mounted separately from fire detection and control equipment and activated by addressable output modules or volt free contacts from other systems via two monitored activation inputs.

The fire detection part of the system has all of the benefits of the popular HFP CP range with its many, easily accessed configuration options and compatibility with a wide range of detection devices.

The HFP CP-XT+ extinguishing modules set a new benchmark for extinguishing control panels. Each module is controlled by its own powerful micro controller bringing unparalleled intelligence and versatility to multi area extinguishing systems for the first time.

HFP CP-XT+ modules have inputs and outputs to cover all system requirements including individual, monitored first and second stage alarms and dual extinguishing outputs. The extinguishing outputs can be configured to operate together or as main and reserve for essential back up following a discharge. They can also be individually calibrated to provide true open and short circuit monitoring through pyrotechnic actuators or a wide range of solenoids.

Powerful Features

In addition to HFP CP-XT+ extinguishing modules, up to seven HFP CP ancillary boards providing zonal and common relay outputs and seven HFP CP sounder boards, each providing an additional eight, monitored sounder circuits can be connected to the HFP CP RS485 serial bus at up to 1200 metres from the control equipment.

Also, up to seven HFP CP-XT ancillary boards and seven HFP Si status units can be connected to each HFP CP-XT+ module to provide remote status indication, control and additional outputs as required at up to 1200 metres. This flexibility ensures that any system configuration can be realised with a minimum of cabling.

Installation

The simple construction of HFP CP-XT+ control panels utilises removable bridge plates for mounting all electronic assemblies. These bridge plates bring the terminals to the front of the enclosure providing easy access to all wiring terminals.

The outer door may be removed to further improve access by withdrawing the easily accessible hinge pins. This ensures clear access for wiring and protection of the electronic assemblies during installation.

Multiple knock-outs in the top, bottom, back and sides of the enclosures provide ample options for cable entries.

Features

- ▶ Fully certified to BS EN54-2 and BS EN54-4
- ▶ 2, 4 or 8 detection zones
- ▶ 1 to 4 extinguishant areas
- ▶ Fire and second stage sounder outputs for each area
- ▶ First and second stage volt free changeover contacts for each area
- ▶ Released volt free contact per area
- ▶ Fault volt free contact per area
- ▶ Programmable extinguishant delays
- ▶ Programmable output duration
- ▶ Extract fan control
- ▶ Countdown indicator shows time until release in seconds
- ▶ Mode select and manual release controls per area
- ▶ Monitored remote manual release input
- ▶ Monitored remote Hold input
- ▶ Monitored remote Mode select (door interlock) input
- ▶ Monitored remote Released pressure switch input
- ▶ Monitored remote Low Pressure switch input
- ▶ Monitored Abort input
- ▶ Dual extinguishant outputs for each area (configurable as Main/Reserve)

HFP CP-XTSI

Extinguishant Status & Ancillary Units

Ancillary PCB Features

- ▶ Two wire serial connection
- ▶ Up to 7 per system
- ▶ 230V AC or 24 VDC powered versions
- ▶ Relay operated LED indicators
- ▶ Volt free relay outputs for fire and extinguishing system status

HFP CP-XTSI Overview

HFP CP-XTSI is a range of system status indicator units for use with Hochiki HFP XT and HFP XT+ extinguishant releasing control panels. The HFP CP-XTSI range of status indicators provide detailed status information for HFP XT and HFP XT+ extinguishant release control equipment.

All models provide high brightness, LED indication of Manual Only, Automatic and Manual, Hold operated Disabled, Imminent and Released conditions. Models are also available with zonal fire indicators and a common fault indicator.

For systems where local control of the Automatic/Manual mode and or a Manual extinguishant release control are required, units are available with these controls fitted.

All models have monitored inputs for the remote connection of Automatic/Manual mode and Hold switches and are provided with a large, LED display which shows a countdown of the time remaining until the extinguishant is released in seconds.

Hold Off Overview

HFP CP-XTSI Hold off units are available with red or green actuators (BS7273-1 recommends white with red button) and are mounted in a single gang, surface mounting enclosure. For flush mounting, the enclosure may be discarded and the unit mounted to a standard UK single gang electrical back box.

The unit has a durable, shrouded push button to prevent accidental operation and a simple 3 wire connection to HFP-XT, HFP-XT+ or HFP CP-XTSI status units is required.

HFP CP-XTSI Hold off units are fitted with normally open and normally closed contacts to allow operation with monitored and unmonitored systems.

Ancillary PCB Overview

The HFP CP-XT Ancillary PCB is compatible with HFP CP-XT and HFP CP-XT+ control panels. The board provides volt free normally open contacts allowing control of sub-systems and plant remotely from the main panel over a two wire data bus.

Mains powered, boxed Ancillary boards require only a two core data cable from the main control panel. 24 VDC versions require an additional two cores for power either from the main panel or from another 24 VDC source.

Up to 7 Ancillary boards can be connected to a control panel and each is allocated an address from 1 to 7 using a binary coded DIL switch. The total length of the data cable from the main panel to the last repeater can be up to 1200 metres.

A mixture of status units and Ancillary boards, up to a maximum of 7 of each type, can be connected to the serial data bus.

Features

- ▶ Approved to EN12094-1, EN54-2 and EN54-4
- ▶ 2, 4 or 8 detection zones
- ▶ Certified compliant with BS EN12094-1 when used with HFP CP-XT
- ▶ High brightness LEDs
- ▶ Detailed indication of the status of the control panel
- ▶ Monitored data connection
- ▶ Countdown timer shows time remaining until release
- ▶ Manual only and Automatic & Manual mode select key-switch option
- ▶ Protected dual action manual release switch option
- ▶ Four wire connection (data and power)
- ▶ Protected dual action manual release switch option
- ▶ Option for zonal fire and common fault indication with buzzer
- ▶ Robust, high quality enclosure
- ▶ Easy access to terminals
- ▶ Remote Auto/Manual door interlock input (monitored)
- ▶ Remote Hold input (monitored)
- ▶ Internal fault diagnosis indicators
- ▶ Weatherproof IP65 versions available
- ▶ Internal buzzer

HFCP-XT Network Diagram

High Integrity Configurable Network

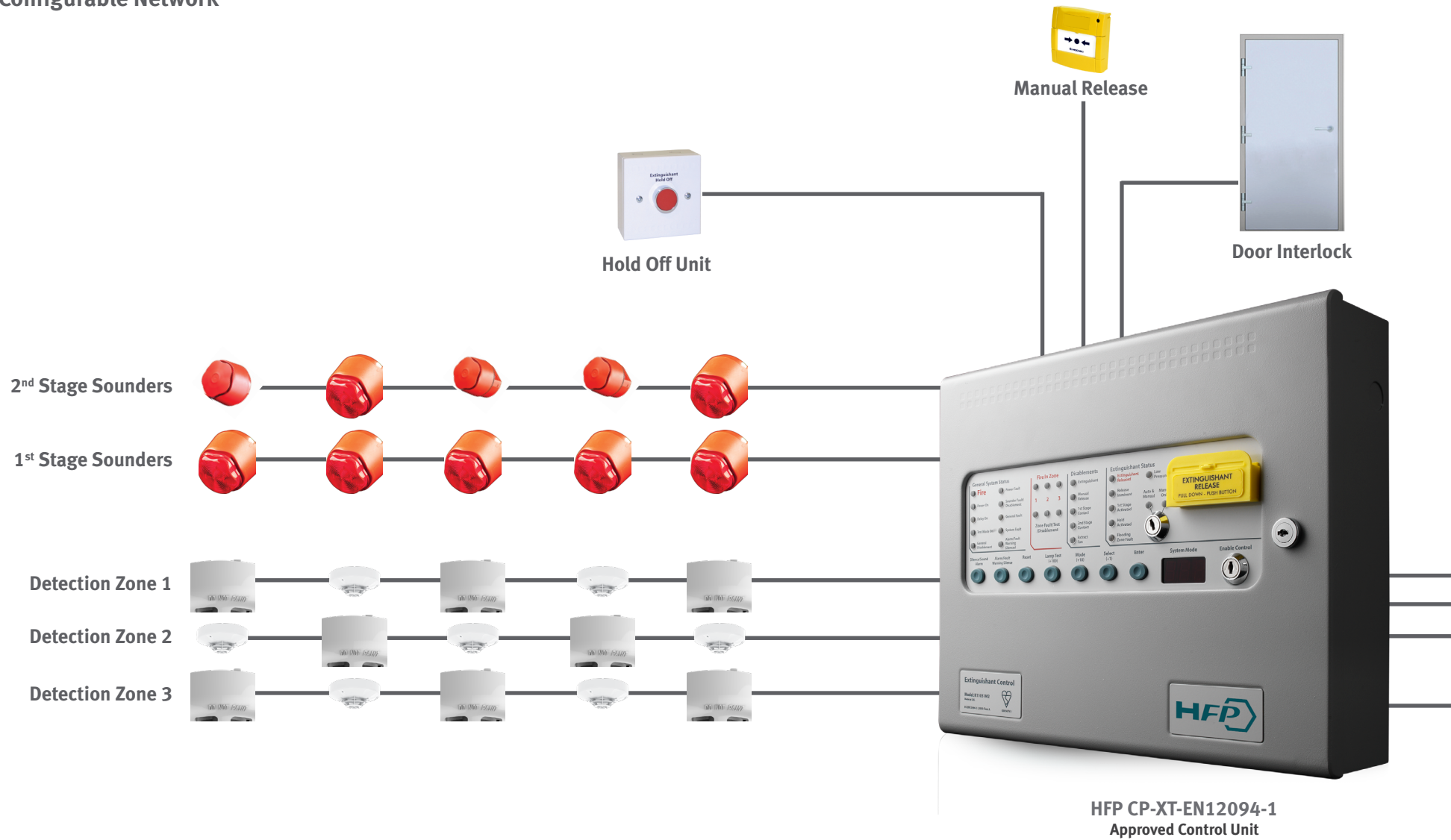

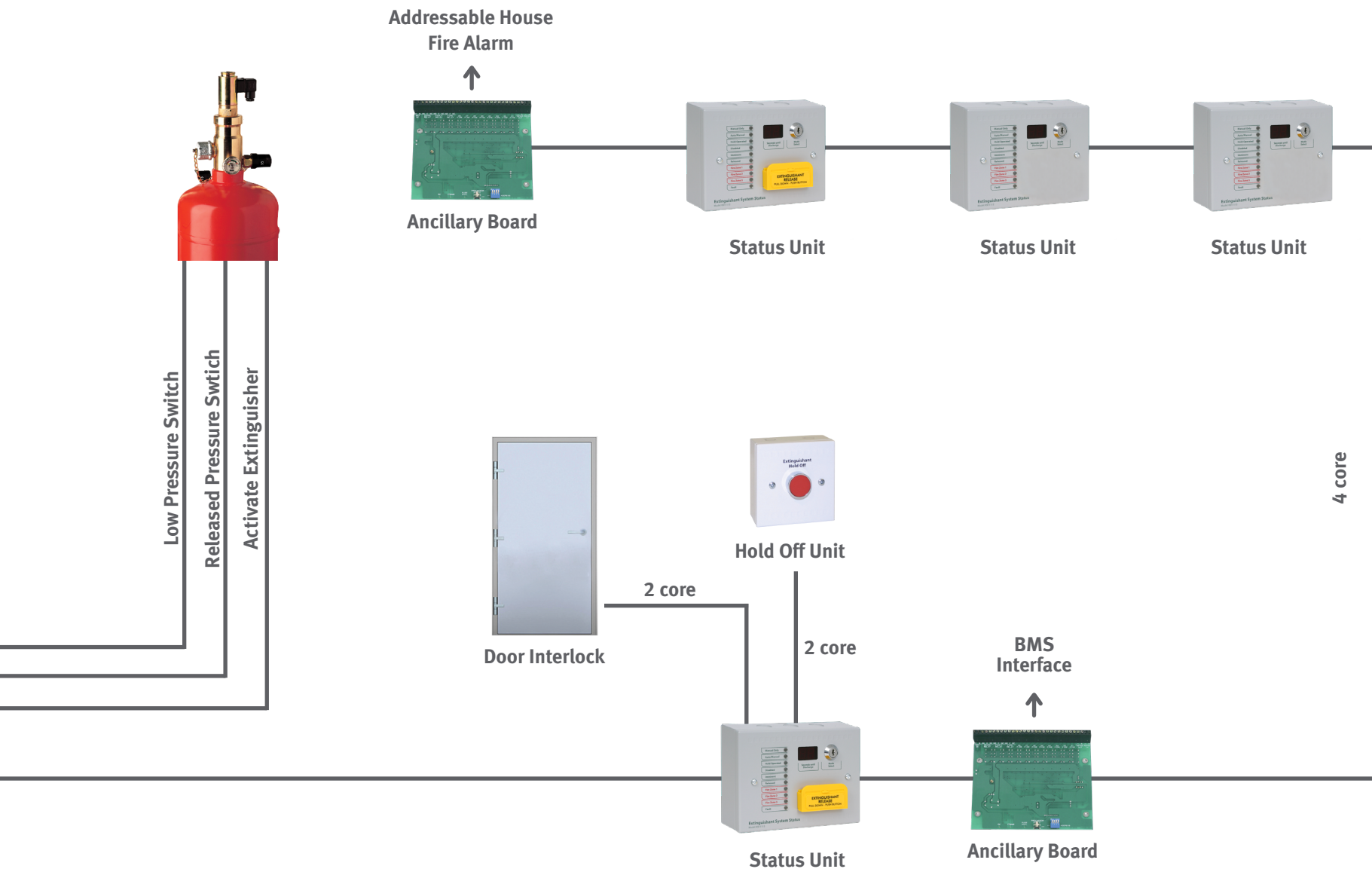



HFP PSU



SO2014 - 2.5A PSU



S406 - 5.25A PSU



S408 - 10.25A PSU

HFP PSU

Power Supplies

The HFP PSU range of 24 VDC power supplies are designed to meet the exacting requirements of fire detection and alarm systems and fire protection systems.

All models charge sealed lead acid batteries using sophisticated, temperature compensated charging and monitoring techniques to keep the batteries in the best possible condition.

Over depletion of batteries is prevented by a low battery voltage disconnection function which removes the load from the batteries when their terminal voltage reduces to a level which would damage them.

A low battery voltage fault warning is given when the batteries reach the minimum terminal voltage recommended by the battery manufacturers.

A high series resistance in the battery supply circuit which would allow the power supply output voltage to fall outside of the specified range is indicated as a fault condition.

All models are fitted with a dual output board to provide redundant power paths for fire alarm applications and are available in a range of enclosures to accommodate different battery sizes.

On-board LED indicators are provided to indicate the status of the unit and an on-board header is available to extend status signals to other systems volt free relay contact that operates upon any fault condition or total power failure.

Enclosures are designed to match both HFP AP and HFP CP fire panel ranges and are constructed from 1.2mm mild steel and are finished with epoxy powder coating.

The HFP PSU boxed range is available in the following power outputs:

- ▶ HFP PSU-2.5/12SS - 2.5A output and up to 12Ah batteries
- ▶ HFP PSU-5.25/26SS - 5.25A output and up to 26Ah batteries
- ▶ HFP PSU-10.25/45SS - 10.25A output and up to 45Ah batteries

Unboxed or caged power supplies for incorporation into other equipment are available as follows:

- ▶ S2014 - 2.5A output
- ▶ S406 - 5.25A output
- ▶ S408 - 10.25A output

ESP

intelligent

Analogue Addressable Fire Detection

Hochiki's comprehensive ESP intelligent (Analogue Addressable range) is suitable for even the most demanding environments and incorporates high performance sensors, a wide selection of input and output modules and ancillaries. All products use Hochiki's high integrity digital communications link 'ESP' (Enhanced Systems Protocol) that's at the heart of the ESP range.

www.hochikieurope.com/esp

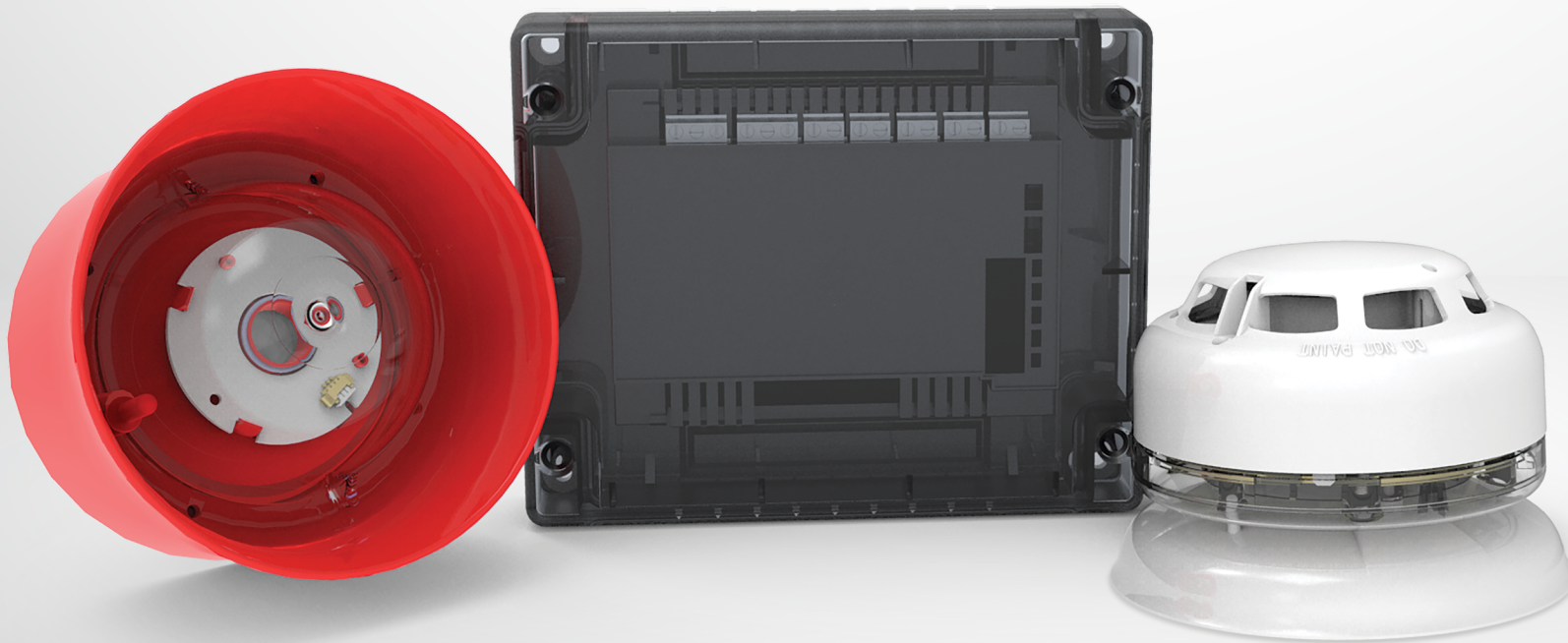



ALN-E(HFP)

A **Optical Smoke Sensor** incorporating Hochiki's unique High Performance Chamber which allows the sensor threshold level to be increased, thereby improving the signal to noise ratio and reducing susceptibility to false alarms.

- ▶ Removable, High Performance Chamber
- ▶ Twin fire LEDs allow 360° viewing
- ▶ Locking mechanism (sensor to base)
- ▶ Variable sensitivity
- ▶ Electronically addressed
- ▶ Approved by LPCB & VdS
- ▶ Pulsing/non-pulsing controlled from panel*¹
- ▶ Addressed via TCH-B200 Hand Held Programmer.

⚓ **ALN-ENM**

⬢ **ALN-EN/SIL**



ATJ-E(HFP)

A **Multi-Heat Sensor** incorporating a variable Fixed Temperature heat element and Rate Of Rise heat element, both controlled from the Control Panel allowing either thermal element or both elements simultaneously to be active in making the fire decision.

- ▶ User selectable modes
- ▶ Incorporates Fixed Temperature and Rate Of Rise Heat elements
- ▶ Twin fire LEDs allow 360° viewing
- ▶ Electronically addressed
- ▶ LPCB & VdS approved to Classes A, B & C
- ▶ Addressed via TCH-B200 Hand Held Programmer
- ▶ Pulsing/non-pulsing controlled from panel*¹.

⚓ **ATJ-ENM**

⬢ **ATJ-EN/SIL**



ACC-E(HFP)

A **Multi Sensor** incorporating a thermal element and a High Performance photoelectric smoke chamber. Has three modes controlled from the Control Panel, allowing either the optical or thermal element or both to be active in making the fire decision.

- ▶ User selectable modes
- ▶ Incorporates Optical & Heat elements
- ▶ Removable, High Performance Chamber
- ▶ Twin fire LEDs allow 360° viewing
- ▶ Variable sensitivity
- ▶ Electronically addressed
- ▶ Addressed via TCH-B200 Hand Held Programmer
- ▶ Pulsing/non-pulsing controlled from panel*¹
- ▶ Approved by LPCB.

⚓ **ACC-ENM**

⬢ **ACC-EN/SIL**



ACD-E(HFP)

Addressable Multi Sensor with CO detection An addressable loop-powered multi-sensor, with smoke, heat and CO sensing elements. The unit offers 24 different modes of operation*¹ and seamlessly matches the other sensors in the ESP Range. The CO sensing element can be used to detect smoke as well as life-threatening CO levels (acting as a CO alarm).

- ▶ User selectable modes
- ▶ Low profile
- ▶ Multiple modes
- ▶ Heat, Optical and CO sensing elements
- ▶ CO Alarm (COHb) facility
- ▶ 10 year CO sensor life
- ▶ Programmable fire threshold level
- ▶ 2 colour LED (Polling: Green, Fire: RED)
- ▶ RI & LED controllable separately if required*¹
- ▶ Pulsing/non-pulsing controlled from panel*¹
- ▶ Addressed via TCH-B200 Hand Held Programmer.



ACB-EW

An **Intelligent IP67 Rated Waterproof Multi-Heat Sensor** which can be used externally and is supplied with its own fixing base which is used to fix the sensor. Flying leads from the sensor connect directly to the loop via waterproof connectors.

- ▶ User selectable modes
- ▶ Incorporates Fixed Temperature and Rate Of Rise Heat elements
- ▶ Twin fire LEDs allow 360° viewing
- ▶ Electronically addressed
- ▶ IP67 rated
- ▶ Supplied with fixing base
- ▶ LPCB & VdS approved to Classes A, B & C
- ▶ Addressed via TCH-B200 Hand Held Programmer & PL-2
- ▶ Pulsing/non-pulsing controlled from panel*¹.

*¹Please ensure control panel compatibility.



ALN-E(HFP)-SCI

An Intelligent Optical Smoke Sensor with SCI incorporating Hochiki's newest High Performance Chamber Technology removing the need to use Ionisation Smoke Sensors in the majority of applications. This also allows the sensor threshold level to be increased, thereby improving the signal to noise ratio and reducing susceptibility to false alarms.

- ▶ Removable, High Performance Chamber
- ▶ Locking mechanism (sensor to base)
- ▶ Variable sensitivity
- ▶ Electronically addressed
- ▶ Twin LEDs allow 360° viewing – green when polling, amber when isolating, red in fire
- ▶ Pulsing/non-pulsing controlled from panel*1.



ATJ-E(HFP)-SCI

An Intelligent Multi-Heat Sensor with SCI which is fully compatible with Hochiki's ESP Analogue Addressable Protocol.

The ATJ-E(SCI) incorporates a Variable Temperature heat element and a Rate of Rise heat element, both of which are controlled from the Control Panel, allowing either thermal element or both elements simultaneously to be active in making the fire decision.

- ▶ User selectable modes
- ▶ Incorporates Fixed Temperature and Rate of Rise Heat elements
- ▶ Electronically Addressed
- ▶ Twin LEDs allow 360° viewing – green when polling, amber when isolating, red in fire
- ▶ Pulsing/non-pulsing controlled from panel*1.



ACC-E(HFP)-SCI

An Intelligent Multi Sensor with SCI which is fully compatible with Hochiki's ESP Analogue Addressable Protocol, and incorporates a thermal element and a High Performance photoelectric smoke chamber.

The ACC-E(SCI) has three modes, which are controlled from the Control Panel, allowing either the optical element or thermal element or both elements to be active in making the fire decision*1.

- ▶ Twin fire LEDs allow 360° viewing
- ▶ User selectable modes
- ▶ Incorporates Optical & Heat elements
- ▶ Removable, High Performance Chamber
- ▶ Variable sensitivity
- ▶ Electronically Addressed
- ▶ Twin LEDs allow 360° viewing – green when polling, amber when isolating, red in fire
- ▶ Pulsing/non-pulsing controlled from panel*1.

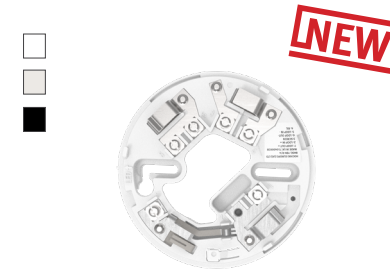

YBV-R/4(HFP)

SCI Sensor Mounting Base which is fully compatible with Hochiki's ESP range of SCI sensors. It is supplied with square cable clamps for secure and reliable cable termination and is also capable of driving a remote LED if required.

- ▶ User selectable modes
- ▶ Electronics free
- ▶ Stainless steel contacts
- ▶ Takes 2.5 mm² cables
- ▶ Slim profile - only 8 mm
- ▶ Rugged wiring contacts
- ▶ Facility for remote indicator
- ▶ Quick Connection via square cable clamps.



ESP FIREbeam

An Addressable Reflective Beam Smoke Detector designed to protect large open spaces, features separate detector and controller. The detector unit incorporates a motorised head that can align itself during commissioning. Additional reflector kits enhance detection range.

- ▶ Approved by VdS
- ▶ Controlled and adjusted from ground level utilising included controller
- ▶ 5-40m standard detection range
- ▶ Extension kits available to enhance detection range up to 100m
- ▶ Fully compatible with the Hochiki ESP analogue addressable protocol
- ▶ Addressed via TCH-B200 Hand Held Programmer & PL-3
- ▶ Continually corrects itself against building movement.

*1 Please ensure control panel compatibility.

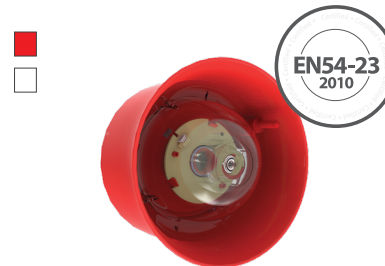
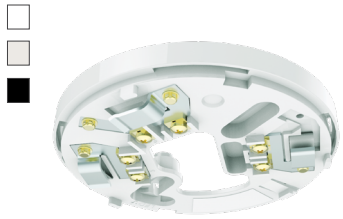

YBN-R/3(HFP)

A Common Mounting Base which is fully compatible with Hochiki's ESP range of sensors. Supplied with square cable clamps for secure and reliable cable termination and is also capable of driving a remote LED if required.

(Red Version - YBO-R/3 (RED) for use with CHQ-WS2 Wall sounder Beacon

- ▶ Electronics free
- ▶ Stainless steel contacts
- ▶ Takes 2.5mm² cables
- ▶ Slim profile - only 8mm
- ▶ Rugged wiring contacts
- ▶ Facility for remote indicator
- ▶ Available in RED for use with CHQ-WS2 Wall Sounder & CHQ-WSB2 Wall Sounder Beacon
- ▶ Quick Connection via square cable clamps.

YBN-R/3(HFP)-SCI

A sensor mounting base featuring an integral short-circuit isolator which will detect and isolate short-circuits on the loop.

- ▶ Features integral SCI
- ▶ Easy to fit
- ▶ Slim profile
- ▶ Matches standard base colours
- ▶ Approved to SIL2
- ▶ Can be used as a standalone isolator with addition of SI-CAP2
- ▶ Compatible with the ESP range of sensors.

CHQ-WS2(HFP)

An Intelligent Loop-Powered Wall Sounder providing 8 volume levels and 51 tones with a maximum output of up to 102 dB(A) (± 2 dB(A)) with low current consumption.

Compatible bases:
YBO-R/3(RED), YBO-R/SCI(RED),
YBO-R/3(WHT) & YBO-R/SCI(WHT-SNDR).

- ▶ Loop Powered
- ▶ Variable Sound Output 90 ~ 102 dB(A) (± 2 dB(A)) output at 1 metre
- ▶ Weatherproof Kit available
- ▶ Auto-shutdown Mode available*¹
- ▶ Approved by LPCB, VdS & to SIL2
- ▶ 51 User-Selectable Tones (all tones EN54-3 compatible)
- ▶ Single Loop Address - addressed via the TCH-B200 Hand Held Programmer.

CHQ-WS2/SIL

CHQ-WSB2(HFP)*²

An Intelligent Loop-Powered Wall Sounder Beacon as per the CHQ-WS2 but additionally featuring an integral beacon within the horn which utilises high intensity LED technology.

As per CHQ-WS2 plus:

- ▶ Variable flash frequency*¹
- ▶ High Intensity LED technology
- ▶ Independent control of Sounder and Beacon*¹
- ▶ Auto-shutdown Mode available - can be set independently for sounder or beacon*¹
- ▶ Approved to EN54-23: 2010 - Category 'O'
- ▶ Addressed via TCH-B200 Hand Held Programmer.

CHQ-WSB2/SIL

YBO-R/3

Is a Sounder Mounting Base which is fully compatible with Hochiki's ESP range of sensors and designed specifically for the Hochiki range of wall sounders, the CHQ-WS2 Wall Sounder and the CHQ-WSB Wall Sounder Beacon.

It is supplied with square cable clamps for secure and reliable cable termination.

- ▶ Electronics free
- ▶ Stainless steel contacts
- ▶ Takes 2.5 mm² cables
- ▶ Slim profile - only 13 mm
- ▶ Rugged wiring contacts
- ▶ Also available in white
- ▶ Quick Connection via square cable clamps.

*¹Please ensure control panel compatibility. *²For product variants, see pages 77 to 80.

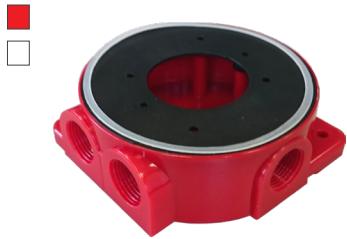

CHQ-WPK

A Weatherproof Back Box and gasket set for the CHQ-WS2 Wall Sounder, CHQ-CB Ceiling Beacon, CHQ-WB Wall Beacon and CHQ-WSB2 Wall Sounder Beacon, increases the IP Rating of the Sounder to IP65 for external use.

- ▶ Easy to install
- ▶ Increases sounder IP Rating from IP21 to IP65 (external use)
- ▶ Increases beacon IP rating from IP21 to IP33 (external use).



YBO-BS(HFP)

An Intelligent Loop-Powered Base Sounder providing 13 volume levels and 51 tones with a maximum output of up to 98 dB(A) (± 2 dB(A)) with low current consumption.

Compatible bases:
YBN-R/3 or YBN-R/3(SCI) Bases.

- ▶ Loop Powered
- ▶ Single Loop Address - addressed automatically by Control Panel or via the TCH-B200 Hand Held Programmer
- ▶ 50 ~ 98 dB(A) (± 2 dB(A)) output at 1m
- ▶ Fits Hochiki Standard or Isolator Base and supports ESP Sensors, Beacons and Remote Indicator
- ▶ Approved by LPCB, VdS & to SIL2
- ▶ 51 User-Selectable Tones (all tones EN54-3 compatible).

◆ YBO-BS/SIL



YBO-BSB2(HFP)*2

An Intelligent Loop-Powered Base Sounder Beacon providing 13 volume levels and 51 tones with a maximum output of up to 98 dB(A) (± 2 dB(A)) with low current consumption.

Compatible bases:
YBN-R/3 or YBN-R/3(SCI) Bases.

- ▶ Loop Powered
- ▶ Single Loop Address, addressed by either Control Panel or TCH-B200
- ▶ 50 ~ 98 dB(A) (± 2 dB(A)) output at 1m
- ▶ Fits Hochiki Standard or Isolator Base and supports ESP Sensors, Beacons and Remote Indicator
- ▶ Beacon and Sounder can be controlled independently*1
- ▶ Approved to EN54-23: 2010 - Category 'O'
- ▶ 51 User-Selectable Tones (all tones EN54-3 compatible).

◆ YBO-BSB2/SIL



CHQ-CB(HFP)*2

An Intelligent Loop-Powered Ceiling Beacon with a high-intensity LED and a custom designed free-form optic which produce a highly visible flash. Variants available in 5m, 7.5m, 10m and 15m area coverage.

- ▶ High Intensity LED technology
- ▶ 0.5/1 Hz flash frequency
- ▶ Addressable via TCH-B200
- ▶ Choice of 2 LED colours (red and white)
- ▶ Approved to EN54-23: 2010 - Category 'C'
- ▶ High efficiency
- ▶ Selectable light output*1
- ▶ Operating Voltage 17-41 VDC.



CHQ-WB(HFP)*2

An Intelligent Loop-Powered Wall Beacon with a high intensity LED and a custom designed free-form optic which produces a highly visible flash. Variants available in 5m, 7.5m and 10m area coverage.

Compatible bases:
YBN-R/3, YBN-R/3(SCI), YBO-BS or the YBO-R/(SCI)

- ▶ High Intensity LED technology
- ▶ 0.5/1 Hz flash frequency
- ▶ Addressable via TCH-B200
- ▶ Choice of 2 LED colours (red and white)
- ▶ Approved to EN54-23: 2010 - Category 'W'
- ▶ High efficiency
- ▶ Selectable light output*1
- ▶ Operating Voltage 17-41 VDC.



CHQ-ARI(HFP)

An Intelligent Loop-Powered Remote Indicator, with high-intensity LEDs and a Fresnel lens design which produces a highly visible signal. The casing exactly matches the Hochiki ESP Sensor range in shape and colour providing seamless integration.

- ▶ High Intensity LED technology
- ▶ Addressable via TCH-B200
- ▶ Approved by VdS
- ▶ Non EN54-23 Compliant.



CHQ-AB(HFP)

An Intelligent Loop-Powered Visual Indicator with high-intensity LEDs and Fresnel lens design which produces a highly visible flash. The casing exactly matches the Hochiki ESP Sensor range in shape and colour providing seamless integration.

- ▶ High Intensity LED technology
- ▶ 1 Hz flash frequency
- ▶ Addressable via TCH-B200
- ▶ Choice of 3 lens colours (red, amber and blue)
- ▶ Approved by VdS (red and amber lens)
- ▶ Non EN54-23 Compliant
- ▶ Supplementary indicator.

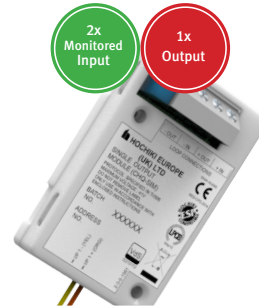

CHQ-POM(HFP)

An Intelligent Powered Output Module designed to supply a nominal 24 VDC at various, user-selectable current levels from 2 to 32 mA (in increments of 2 mA). The unit is small enough to be added to other third-party devices thereby allowing a range of equipment to be added to the ESP loop. The unit also features two monitored inputs.

- ▶ Supplies a nominal 24 VDC at various current levels, 2 mA to 32 mA in increments of 2 mA
- ▶ User-selectable current output
- ▶ Includes two monitored inputs
- ▶ Approved by LPCB & VdS
- ▶ Addressed with TCH-B200 Hand Held Programmer & PL-3
- ▶ Colour-coded flying leads for simple installation
- ▶ Small design, provides simple connectivity to ESP loop for third-party devices, such as IFD-E.



CHQ-SIM(HFP)

An Intelligent Single Input Module designed to allow a single monitored input to be connected to the ESP loop. This provides a compact, low-cost option where the installation of the larger CHQ 'Smart-Fix' Range of Modules might be difficult.

- ▶ Small design for simple provision of a monitored input onto an ESP loop
- ▶ Flying leads for easy installation
- ▶ Addressed with TCH-B200 Hand Held Programmer & PL-3
- ▶ Approved by LPCB & VdS.



CHQ-SOM(HFP)

An Intelligent Single Output Module designed to allow a single relay output to be connected to the ESP loop. The unit incorporates a volt-free relay contact that can be configured as either N/O or N/C, the relay contact is rated to 30 VDC (max), 1 A (resistive load). The CHQ-SOM features three colour-coded flying leads, the unit also features a wiring terminal block for loop connection.

- ▶ Small design for simple provision of a monitored input onto an ESP loop
- ▶ Flying leads for easy installation
- ▶ Approved by LPCB
- ▶ Addressed with TCH-B200 Hand Held Programmer & PL-3.

Lid Colours

- Transparent Black
- Opaque White

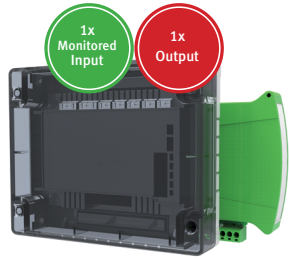

Lid Colours

- Transparent Black
- Opaque White

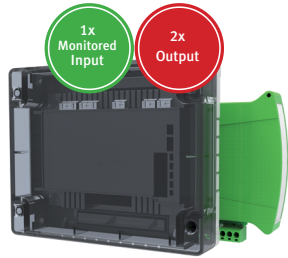

Lid Colours

- Transparent Black
- Opaque White

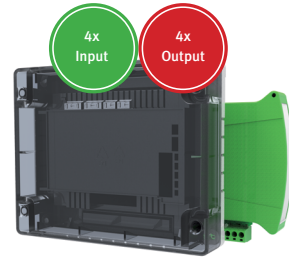

Lid Colours

- Transparent Black
- Opaque White

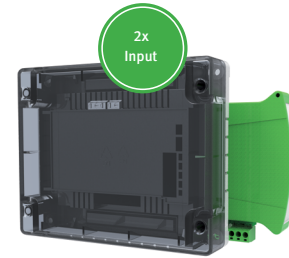

Lid Colours

- Transparent Black
- Opaque White

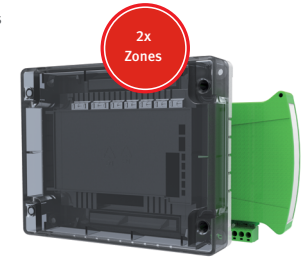

CHQ-MRC2(HFP)-SCI

An Intelligent Mains Relay Controller providing a single mains rated relay output for the control of such devices as dampers, extractors or plant and equipment shut-down. The monitored input can be used for local power supply fault monitoring or as a general-purpose input. Also available as a DIN Rail mountable version. Both models feature an integral short-circuit isolator.

- ▶ 1 x mains out & 1 x input
- ▶ Loop-powered
- ▶ Single loop address
- ▶ DIL switch addressable
- ▶ Single mains rated relay contact
- ▶ Relay contact rated at 250 VAC @ 5A (resistive) & 48 VDC @ 2A (resistive)
- ▶ Auxiliary monitored input
- ▶ Both models approved by LPCB
- ▶ Can be used with CHQ-BACKBOX to comply with BS 7671.

■ CHQ-MRC2/DIN(SCI)

CHQ-DRC2(HFP)-SCI

An Intelligent Dual Relay Controller designed to provide two general-purpose relay outputs, each output can be controlled independently and used to control dampers, plant and equipment shut-down. The monitored input can be used for local power supply fault monitoring or as a general-purpose input. Also available as a DIN Rail mountable version. Both models feature an integral short-circuit isolator.

- ▶ Loop powered
- ▶ Single loop address
- ▶ DIL switch addressable
- ▶ Relays contact rated at 30 VDC at 1 A
- ▶ Auxiliary monitored input
- ▶ Both models approved by LPCB & VdS
- ▶ Deeper back box available CHQ-BACKBOX
- ▶ Two independently controlled changeover relays
- ▶ Can be used with CHQ-BACKBOX to comply with BS 7671.

⚓ CHQ-DRC2/M(SCI)

◆ CHQ-DRC2(SCI)/SIL

■ CHQ-DRC2/DIN(SCI)

CHQ-PCM(HFP)-SCI

A Plant Control Module with four independent change-over relay outputs, with N/O and N/C volt free contacts and four inputs. These outputs can be driven separately by the fire alarm control panel and can be used for the control of devices such as dampers or for plant and equipment shut-down. Also available as a DIN Rail mountable version. Both models feature an integral short-circuit isolator.

- ▶ 4 x inputs & 4x outputs
- ▶ Single loop address
- ▶ Loop powered
- ▶ DIL switch addressable
- ▶ 4 change-over relay outputs
- ▶ 4 independent inputs for monitoring of volt-free contacts
- ▶ Both models approved by LPCB
- ▶ Deeper back box available CHQ-BACKBOX
- ▶ Can be used with CHQ-BACKBOX to comply with BS 7671.

◆ CHQ-PCM(SCI)/SIL

■ CHQ-PCM/DIN(SCI)

CHQ-DIM2(HFP)-SCI

An Intelligent Dual Input Module designed to interface to a variety of inputs such as door contacts, sprinkler flow/door switches and plant equipment. Also available as a DIN Rail mountable version. Both models feature an integral short-circuit isolator.

- ▶ Loop powered
- ▶ Single loop address
- ▶ DIL switch addressable
- ▶ Each input can be configured to operate on either an open or short-circuit.
- ▶ Both models approved by LPCB & VdS
- ▶ Can be used with CHQ-BACKBOX to comply with BS 7671.

⚓ CHQ-DIM2/M(SCI)

◆ CHQ-DIM2(SCI)/SIL

■ CHQ-DIM2/DIN(SCI)

CHQ-DZM(HFP)-SCI

An Intelligent Dual Zone Module designed to allow up to 60 conventional detectors (30 per zone) or up to 6 SPC-ET (3 per zone) to be interfaced to Hochiki's ESP analogue addressable system. The unit also features Schottky and Zener line continuity options. Also available as a DIN Rail mountable version. Both models feature an integral short-circuit isolator.

- ▶ 2 x zonal inputs
- ▶ Single loop address
- ▶ Supports two independent zones of conventional detectors
- ▶ DIL switch addressable
- ▶ Requires an auxiliary 24 VDC supply
- ▶ Both models approved by LPCB
- ▶ Deeper back box available CHQ-BACKBOX
- ▶ Both zones fully monitored for Open and short Circuit
- ▶ Can be used with CHQ-BACKBOX to comply with BS 7671.

◆ CHQ-DZM(SCI)/SIL

■ CHQ-DZM/DIN(SCI)

Lid Colours

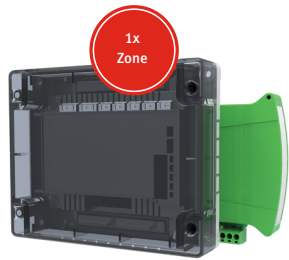

Lid Colours

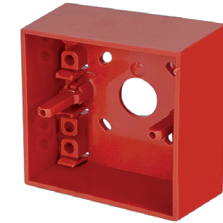
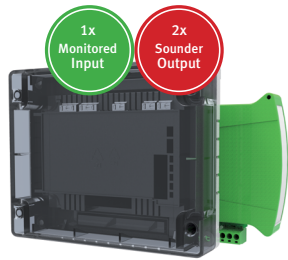

CHQ-SZM2(HFP)-SCI

An Intelligent Single Zone Monitor designed to allow up to 6 conventional detectors or 1 beam detector to be interfaced to Hochiki's ESP analogue addressable system. Also available as a DIN Rail mountable version. Both models feature an integral short-circuit isolator.

- ▶ 1 x zonal input
- ▶ Loop powered
- ▶ Up to 6 Conventional Detectors
- ▶ DIL switch addressable
- ▶ Single loop address
- ▶ Remote LED output
- ▶ Both models approved by LPCB & VdS
- ▶ Deeper back box available CHQ-BOX
- ▶ Fully monitored for Open and Short Circuit faults
- ▶ Can be used with CHQ-BACKBOX to comply with BS 7671.

🔗 **CHQ-SZM2/M(SCI)**

📏 **CHQ-SZM2/DIN(SCI)**

CHQ-DSC2(HFP)-SCI

An Intelligent Dual Sounder Controller which has been designed to provide two sounder outputs (that can be driven separately) with full fault monitoring. The monitored input can be used for local power supply fault monitoring or as a general-purpose input. Also available as a DIN Rail mountable version. Both models feature an integral short-circuit isolator.

- ▶ Single loop address
- ▶ Two independent sounder circuits
- ▶ DIL switch addressable
- ▶ Each circuit fully monitored for Open and Short Circuit faults
- ▶ Each alarm circuit fused at 1 A
- ▶ Auxiliary monitored Input
- ▶ Outputs are synchronised and can be driven continuously or intermittently
- ▶ 24 VDC auxiliary power required
- ▶ Both models approved by LPCB & VdS
- ▶ Can be used with CHQ-BACKBOX to comply with BS 7671.

🔗 **CHQ-DSC2/M(SCI)**

📏 **CHQ-DSC2(SCI)/SIL**

📏 **CHQ-DSC2/DIN(SCI)**

HCP-E(HFP)-SCI

An Intelligent Manual Call Point Isolator fully compatible with Hochiki's ESP analogue addressable protocol and featuring an integral short-circuit isolator (SCI). Features a bi-coloured LED to indicate either fire (red) or short-circuit (amber). Also features plug-in wiring terminals for easy installation.

- ▶ Fast response
- ▶ Integral short-circuit isolator
- ▶ Bi-colour status LED
- ▶ Non-frangible element fitted as standard (conforms to EN54)
- ▶ Addressed with TCH-B200 Hand Held Programmer & PL-3
- ▶ Surface or flush mounting
- ▶ LPCB Approved to EN54
- ▶ Approved to SIL2.

🔗 **HCP-EM(SCI)**

📏 **HCP-E(SCI)/SIL**

HCP-W(HFP)-SCI

An Intelligent IP67 Weatherproof Manual Call Point Isolator fully compatible with Hochiki's ESP analogue addressable protocol and featuring an integral short-circuit isolator (SCI). Features a bi-coloured LED to indicate either fire (red) or short-circuit (amber). Also features plug-in wiring terminals for easy installation.

- ▶ Fast response
- ▶ Integral short-circuit isolator
- ▶ Bi-colour status LED
- ▶ Non-frangible element fitted as standard (conforms to EN54)
- ▶ Addressed with TCH-B200 Hand Held Programmer & PL-3
- ▶ Surface mounting
- ▶ LPCB Approved to EN54
- ▶ IP67 rated
- ▶ Approved to SIL2.

🔗 **HCP-WM(SCI)**

📏 **HCP-W(SCI)/SIL**

SR BACKBOX

Call Point Surface Mounting Box for HCP-E(SCI) Allows addressable call point HCP-E to be surface mounted.



PS200

Hinged cover for Call Point. An acrylic hinged cover for the HCP-E(SCI) manual call point range which protects against accidental operation/vandalism.

- ▶ Easy to install
- ▶ Protects against accidental activation
- ▶ Requirement under BS5839.



TCH-B200

A Hand Held Address Programmer designed to address the ESP range of Sensors and other intelligent devices such as the YBO-BS Base Sounder. Designed to be light, robust and easy to use it operates from a single PP3 size battery which can provide up to 8000 operations.

- ▶ Lightweight design
- ▶ Quick and reliable addressing
- ▶ Up to 8000 address settings from one battery
- ▶ Displays sensor analogue value.

CDX

conventional

Conventional Fire Detection

Hochiki's CDX range offers one of the most extensive product portfolios available, providing solutions for most conventional fire detection applications as well as security systems, due to its wide operating voltage range (9.5~30 VDC).

www.hochikieurope.com/cdx

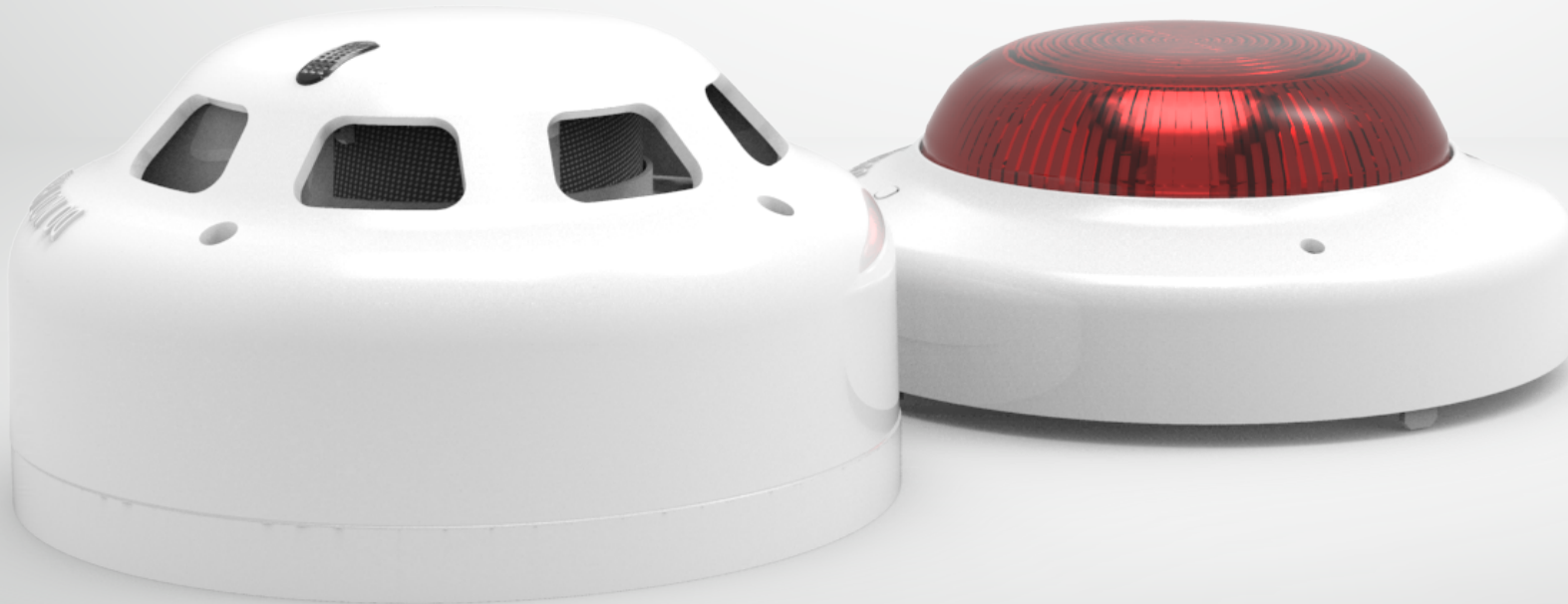



SOC-E3N(HFP)

A Conventional Photoelectric Smoke Detector which is fully compatible with the majority of existing Conventional systems.

- ▶ Removable, High Performance chamber
- ▶ Remote Indicator output
- ▶ Wide voltage range (12 ~ 30 VDC)
- ▶ Low profile design with one piece outer cover
- ▶ Single fire LED - 360° viewing
- ▶ Range of mounting bases
- ▶ Approved by LPCB
- ▶ Automatic Sensitivity Window Verification (ASWV) – Drift Compensation Technology

⚓ SOC-E3NM



DCD-AE3(HFP)

A Conventional Rate of Rise Heat Detector incorporating a 60°C fixed temperature element. The thermistor and linearising circuit provide an accurate linear response Heat Detector. A third terminal provides integral remote indicator output.

- ▶ Electronic linear heat detection
- ▶ Remote Indicator output
- ▶ Wide voltage range (9.5 ~ 30 VDC)
- ▶ Twin fire LEDs allow 360° viewing
- ▶ Range of mounting bases
- ▶ Approved by LPCB & VdS

⚓ DCD-A3M



DCD-CE3(HFP)

A Conventional Rate of Rise Heat Detector incorporating a 90°C fixed temperature element. The thermistor and linearising circuit provide an accurate linear response Heat Detector. A third terminal provides integral remote indicator output.

- ▶ Electronic linear heat detection
- ▶ Remote Indicator output
- ▶ Wide voltage range (9.5 ~ 30 VDC)
- ▶ Twin fire LEDs allow 360° viewing
- ▶ Full range of mounting bases
- ▶ Approved by LPCB & VdS

⚓ DCD-CE3M



DFJ-AE3(HFP)

A Conventional 60°C Fixed Temperature Heat Detector using a thermistor and linearising circuit to provide an accurate linear response Heat Detector. A third terminal provides integral remote indicator output.

- ▶ Electronic linear heat detection
- ▶ Remote Indicator output
- ▶ Wide voltage range (9.5 ~ 30 VDC)
- ▶ Twin fire LEDs allow 360° viewing
- ▶ Fixed Temperature Detector
- ▶ Full range of mounting bases
- ▶ Approved by LPCB & VdS



DFJ-CE3(HFP)

A Conventional 90°C Fixed Temperature Heat Detector using a thermistor and linearising circuit to provide an accurate linear response. A third terminal provides integral remote indicator output.

- ▶ Electronic linear heat detection
- ▶ Wide voltage range - can be installed on security systems
- ▶ Twin fire LEDs allow 360° viewing
- ▶ Fixed Temperature Detector
- ▶ Full range of mounting bases
- ▶ Approved by LPCB & VdS



DFG-60BLKJ

An IP67 Waterproof Conventional 60°C Fixed Temperature Heat Detector with minimal standby current and high reliability. Particularly suited to environments, which are exposed to high levels of condensation or are hosed down.

- ▶ Waterproof design – rated to IP67
- ▶ Low profile shape
- ▶ Utilises a bi-metallic strip to sense temperature change
- ▶ No Mounting base required
- ▶ Minimal standby current
- ▶ Approved by LPCB & VdS



DRD-E

A Conventional Flame Detector designed for internal use to detect large flames. The detector fits any of the CDX range of mounting bases. The detection zone is a 90° cone and the detection range is up to and including 25m.

- ▶ Class 1 performance as defined in
- ▶ BS EN54-10:2002 (range up to 25m)
- ▶ Single IR technology
- ▶ Robust and slim design
- ▶ Low current consumption
- ▶ Easy to install
- ▶ Twin LEDs for 360° view
- ▶ Approved by LPCB & VdS
- ▶ Fits any of the CDX Range of mounting bases



IFD-E

A Conventional IR³ Infrared Flame Detector designed to respond to low-frequency (1 to 15Hz) flickering IR radiation emitted from flames during combustion, the unit can discriminate between flames and spurious sources of radiation such as sunlight. An I.S. version and an explosion-proof version are also available.

- ▶ Triple IR sensor
- ▶ Class 1 sensitivity to EN54-10 detects 0.1m² fire @ 25m
- ▶ Excellent optical interference immunity (solar blind)
- ▶ Selectable output options - conventional
- ▶ 2-wire, 4-20 mA, latching or non-latching relay contacts, fire/fault, pre-alarm
- ▶ Selectable response speed
- ▶ Optical self-test
- ▶ Low power consumption
- ▶ Approved by LPCB
- ▶ SIL Capable



16591

A UV/Dual IR Flame Detector, Alloy Housing Model 16591 is an IR² flame detector with an additional UV detection element, designed for use where open flaming fires may be expected and responds to the light emitted from flames during combustion.

The detector discriminates between flames and other light sources by responding only to particular optical wavelengths and flame flicker frequencies. This enables the detector to avoid false alarms due to such factors as flickering sunlight.

- ▶ Highest immunity to false sources
- ▶ Suitable for indoor and outdoor areas
- ▶ Selectable response speed
- ▶ Optical self-test
- ▶ Low power consumption
- ▶ Approved to EN54
- ▶ Detects invisible flames from fuels such as Hydrogen and other inorganic fuels



16091

A Hand Held Flame Detector Tester providing a flame-free method of UV testing the industrial IR³ series of flame detectors: IFD-E, IFD-E(IS) and the IFD-E(Exd).

THIS EQUIPMENT IS ALSO AVAILABLE FOR HIRE. Please contact your Sales Representative for further information.

- ▶ Tests many Flame Sensors Types UV, UV/IR, UV/IR², IR³, IR², IR
- ▶ Range typically 3m and beyond
- ▶ Selectable optical output intensity with LED bar graph indication
- ▶ Flame-free UV testing, ideal for hazardous areas
- ▶ Simple to use hand held unit with rechargeable NiCd battery pack and charger



SPC-ET(HFP)

A Conventional Beam Smoke Detector that consists of an emitter and receiver that cover a distance of 5 - 100m providing a maximum coverage of 1500m². Features an automatic signal strength adjustment facility and is also available with a latching or a non-latching relay.

- ▶ 5 - 100m range
- ▶ Automatic compensation
- ▶ Automatic signal strength adjustment
- ▶ Can be interfaced onto ESP system via CHQ-DZM(SCI) or CHQ-SZM2(SCI)
- ▶ Approved by LPCB & VdS
- ▶ Emitter unit can be powered direct from zone (or loop)



YBN-R/6(HFP)

A Conventional Detector Mounting Base associated with the CDX Range of Detectors and Beacons and is fully compatible with the majority of existing conventional fire alarm control panels.

- ▶ Integral remote indicator output
- ▶ Low Profile, only 8mm
- ▶ Rugged design and electronics free
- ▶ Quick connections via square cable clamps
- ▶ Accepts up to 2.5mm² cables
- ▶ Bayonet slot, low insertion force for detectors



YBO-R/6PA

A Conventional Detector Mounting Base for 2-Wire systems where detectors and sounders are on same zone cables*.

- ▶ Integral remote indicator output
- ▶ Rugged design
- ▶ Dedicated cable screen terminal
- ▶ Quick connection via square cable clamps
- ▶ Accepts up to 2.5mm² cables
- ▶ Bayonet slot, low insertion force for detectors



YBO-R/6R(HFP)

A Conventional Latching Relay Detector Mounting Base associated with the CDX Range of Detectors and is fully compatible with the majority of existing conventional fire alarm and security control panels.

- ▶ Integral remote indicator output
- ▶ Rugged design
- ▶ Quick connections via square cable clamps
- ▶ Accepts up to 2.5mm² cables
- ▶ Bayonet slot, low insertion force for detectors
- ▶ Approved by LPCB
- ▶ Wide voltage range - can be used in security systems



YBO-R/6RN

A Conventional Non-Latching Relay Detector Mounting Base associated with the CDX Range of Detectors and is fully compatible with the majority of existing conventional fire alarm and security control panels.

- ▶ Integral remote indicator output
- ▶ Wide voltage range - can be used in security systems
- ▶ Rugged design
- ▶ Quick connections via square cable clamps
- ▶ Accepts up to 2.5mm² cables
- ▶ Bayonet slot, low insertion force for detectors
- ▶ Approved by LPCB



YBO-R/6RS

A Conventional Latching Schottky Diode Relay Detector Mounting Base associated with the CDX Range of Detectors and is fully compatible with the majority of existing conventional fire alarm control panels.

- ▶ Integral remote indicator output
- ▶ In-line Schottky Diode for Line Continuity
- ▶ Rugged design
- ▶ Quick connections via square cable clamps
- ▶ Accepts up to 2.5mm² cables
- ▶ Bayonet slot, low insertion force for detectors
- ▶ Approved by LPCB

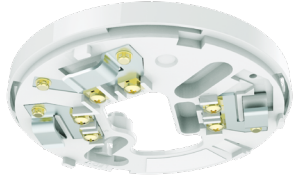

YBN-R/6SK

A Conventional Detector Mounting Base with in-line Schottky Diode, associated with the CDX Range of Detectors and is fully compatible with the majority of existing conventional fire alarm control panels.

- ▶ Integral remote indicator output
- ▶ In-line Schottky Diode for line continuity
- ▶ Low profile, only 8mm
- ▶ Rugged design
- ▶ Quick connections via square cable clamps
- ▶ Accepts 2.5mm² cables
- ▶ Bayonet slot, low insertion force for detectors



CSB-E

A Conventional Base Sounder which has been designed to complement the CDX range of detectors. Improved electronic design enables very low current consumption whilst providing a range of tones and volumes selectable from each unit.

- ▶ Robust design
- ▶ Low current consumption
- ▶ Easy to install
- ▶ Maximum 93 dB(A) @ 1m (Tone 1)
- ▶ 32 user-selectable tones and 3 user-selectable volumes
- ▶ Lockable cap available (CS/CAP)



CSBB-E

A Conventional Base Sounder Beacon which has been designed to complement the CDX range of detectors. Improved electronic design enables very low current consumption whilst providing a range of tones and volumes selectable from each unit. Features integral beacon.

- ▶ Robust design
- ▶ Low current consumption
- ▶ Easy to install
- ▶ Maximum 93 dB(A) @ 1m (Tone 1)
- ▶ 32 user-selectable tones and 3 user-selectable volumes
- ▶ Utilises high intensity LEDs
- ▶ Lockable cap available (CS/CAP)
- ▶ Supplementary indicator
- ▶ Non EN54-23 compliant



CWSB-E

A Conventional Wall Sounder Beacon with improved electronic design enables very low current consumption whilst providing a range of tones and volumes selectable from each unit. Features integral beacon.

- ▶ Robust design
- ▶ Low current consumption
- ▶ Easy to install
- ▶ Maximum 113 dB(A) @ 1m (Tone 15)
- ▶ 32 user-selectable tones
- ▶ Utilises high intensity LEDs
- ▶ Supplementary indicator
- ▶ Non EN54-23 compliant



BANSHEE EXCEL

An Electronic Conventional Sounder which can be installed internally.

- ▶ Robust design
- ▶ Low current consumption
- ▶ Easy to install
- ▶ Maximum 110 dB(A) at 1m (dependent on tone selected)
- ▶ 32 user-selectable tones
- ▶ Approved by VdS



BANSHEE EXCEL IP66

An Electronic Conventional Sounder comes with a deeper IP66 back box, which enables the unit to be installed externally.

- ▶ Robust design
- ▶ Low current consumption
- ▶ Easy to install
- ▶ Deep base provides IP66 protection
- ▶ Maximum 110 dB(A) at 1m (dependent on tone selected)
- ▶ 32 user-selectable tones
- ▶ Approved by VdS



BANSHEE EXCEL LITE

An Electronic Conventional Sounder Beacon which can be installed internally.

- ▶ Robust design
- ▶ Low current consumption
- ▶ Easy to install
- ▶ Xenon beacon technology
- ▶ Maximum 110 dB(A) at 1m (dependent on tone selected)
- ▶ 32 user-selectable tones
- ▶ Approved by VdS
- ▶ Supplementary indicator
- ▶ Non EN54-23 compliant



BANSHEE EXCEL LITE IP66

An Electronic Conventional Sounder Beacon comes with a deeper IP66 back box, which enables the unit to be installed externally.

- ▶ Robust design
- ▶ Low current consumption
- ▶ Easy to install
- ▶ Xenon beacon technology
- ▶ Deep base provides IP66 protection
- ▶ 32 user-selectable tones
- ▶ Approved by VdS
- ▶ Supplementary indicator
- ▶ Non EN54-23 compliant
- ▶ Maximum 110 dB(A) at 1m (dependent on tone selected)



CLB-E(HFP)

A Conventional Visual Indicator for use on 24 V Sounder Circuits. The unit is fitted with a Fresnel lens and high-intensity LEDs, a design which produces a highly visible flash. The casing exactly matches the CDX Detector range in shape and colour providing seamless integration.

- ▶ High Intensity LED technology
- ▶ Fits standard CDX base (YBN-R/6)
- ▶ Supplementary indicator
- ▶ Not EN54-23 compliant
- ▶ Colour-matched to existing detector and base ranges



CWST-S5

A **Conventional Beacon** which features high output LEDs, advanced optics and an innovative lens design, providing outstanding Omni-directional light coverage at low current draw. Specifically designed for, and approved to meet EN54-23. CWST-S5 delivers quality, reliability and long operational life.

- ▶ Approved to EN54-23, C & W categories*
- ▶ Advanced optics ensures superior light coverage at low current draw
- ▶ Available in either red or white casings
- ▶ Available with either a red or white LED
- ▶ Synchronised flash exceeds EN54-23 standard
- ▶ Soft start feature reduces power surges during system start-up



CWST-W5

A **Conventional Weatherproof Beacon**, which features high output LEDs, advanced optics and an innovative lens design, providing outstanding Omni-directional light coverage at low current draw. Specifically designed for, and approved to meet EN54-23. Weatherproof base provides IP65 for external use applications.

- ▶ Approved to EN54-23, C & W categories*
- ▶ Available in either red or white casings
- ▶ Available with either a red or white LED
- ▶ Synchronised flash exceeds EN54-23 standard
- ▶ Soft start feature reduces power surges during system start-up
- ▶ Advanced optics ensures superior light coverage at low current draw



MBF-6EV

A **Conventional Alarm Bell** six inches diameter and for internal use, based upon the industry standard KOBELL range.

- ▶ Low profile
- ▶ Low current consumption
- ▶ Fully suppressed and polarised
- ▶ 95 dB(A) at 1m (typ)
- ▶ Approved by LPCB
- ▶ Simple installation with multi-fixing base plate



FB/024/R/W

A **Conventional Alarm Bell** six inches diameter, which has the same operation as the MBF-6EV except it comes equipped with a weatherproof back box enabling it to be used externally.

- ▶ Low profile
- ▶ Low current consumption
- ▶ Fully suppressed and polarised
- ▶ 100 dB(A) at 1m (typ)
- ▶ Weatherproof for external installation
- ▶ Approved by LPCB
- ▶ Simple installation with multi-fixing base plate

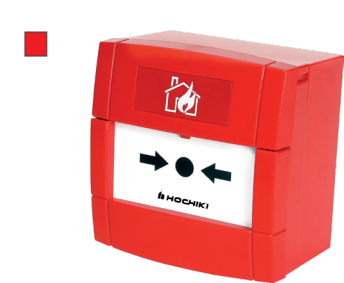

CCP-E

A **Conventional Manual Call Point** based upon the industry standard KAC world series housing. The unit can support either a 'Frangible Glass' element or a 'Non Frangible Plastic' element. It is also supplied complete with SR-BACKBOX for surface mounting.

Note - Yellow version not EN54 compliant

- ▶ Approved to EN54-11:2001
- ▶ Other colours available on request
- ▶ Approved by LPCB
- ▶ Terminals can accommodate up to a 2.5mm² solid conductor

⚓ MCP1A



CCP-W

An IP67 Conventional Weatherproof Call Point which can be used externally.

- ▶ Approved to EN54-11:2001
- ▶ Supplied with back-box as standard
- ▶ Other colours available on request
- ▶ Ingress Protection rated to IP67
- ▶ Approved by LPCB
- ▶ Terminals can accommodate up to a 2.5mm² solid conductor

⚓ MCP1A

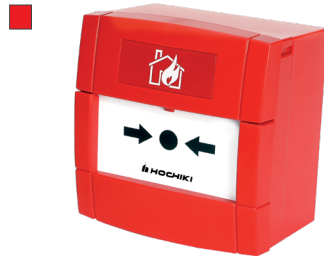

CCP-SAVWIRE

Conventional Sawwire Call Point Red based upon the industry standard KAC world series housing and features easy to install, push-fit wiring terminals. The unit has been specifically designed for use on “Sawwire” (two-wire) systems.

The unit can support either a ‘Frangible Glass’ element or a ‘Non Frangible Plastic’ element.

- ▶ Approved to EN54-11:2001
- ▶ Terminals can accommodate up to a 2.5mm² solid conductor
- ▶ Designed for use on “Sawwire” (two-wire) systems



CCP-KS

Conventional Key Switch Manual Call-Point based upon the industry standard KAC 9000 series housing and features flying leads for simple wiring.

The unit features two key positions marked as “1” and “0” – with the key easily removable in either position

- ▶ Two position keyswitch (marked 1 and 0)
- ▶ Key removable in both positions
- ▶ Supplied with back box for surface fixing
- ▶ Terminals can accommodate up to a 2.5mm² solid conductor
- ▶ Supplied in RED - other colours available on request
- ▶ Suitable for fire, security and other specialist applications

CDX

Intrinsically Safe & Explosion Proof Conventional Products

Hochiki's CDX range offers one of the most extensive product portfolios available, providing solutions for most conventional fire detection applications as well as security systems, due to its wide operating voltage range (9.5~30 VDC).

www.hochikieurope.com/is

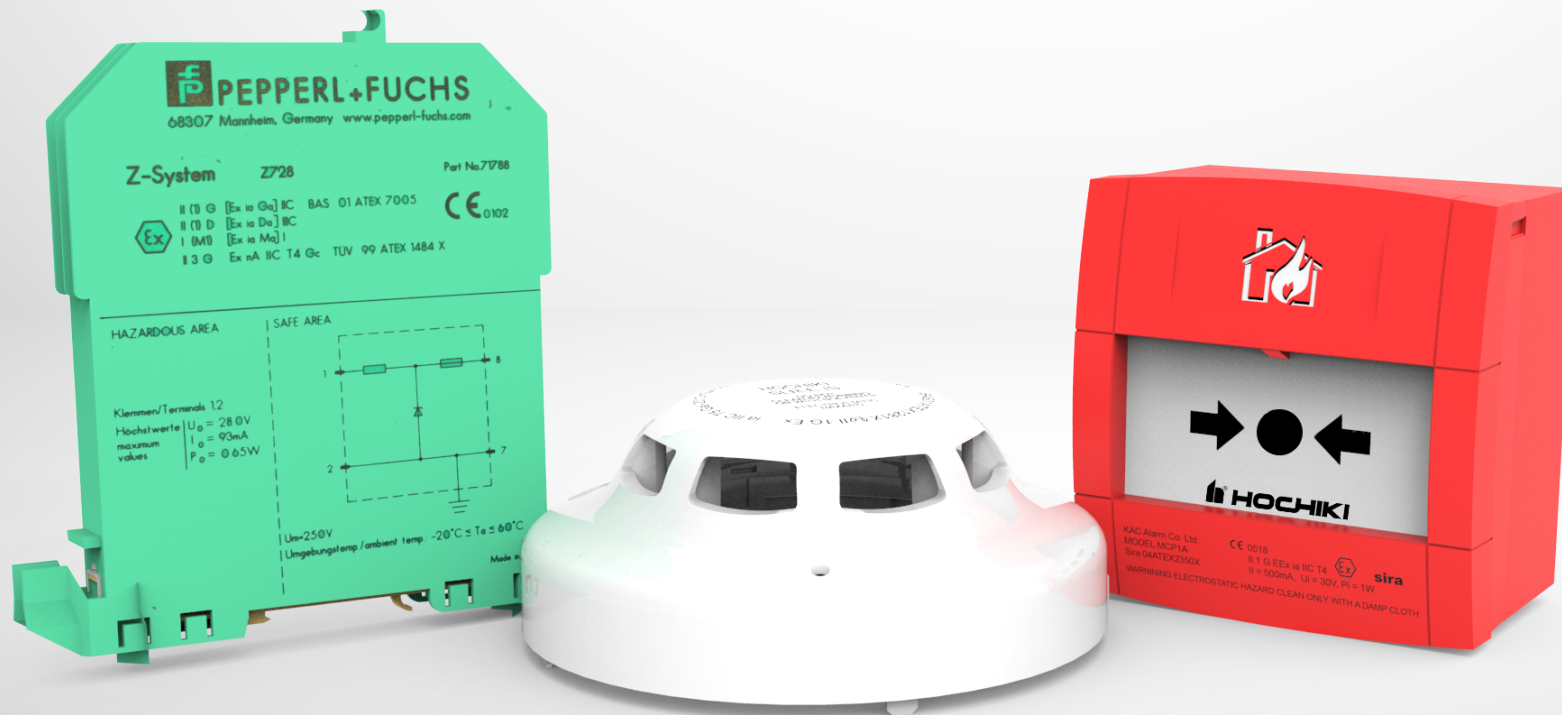



SLR-E-IS

A Conventional I.S. Photoelectric Smoke Detector designed for use in hazardous areas. Incorporates a remote indicator output and a removable chamber for easy maintenance.

- ▶ Removable, High Performance chamber
- ▶ Twin fire LEDs allow 360° viewing
- ▶ Supported by a range of barriers
- ▶ Remote indicator output
- ▶ ATEX certification to: II 1G EEx ia IIC T5 (Tamb=55°C)
- ▶ Suitable for installation in areas at Category 1 (inc all lower categories)
- ▶ Approved by LPCB, GL and to IECEx

⚓ SLR-E-IS

◆ SLR-E-IS/SIL



DCD-1E-IS

A Conventional I.S. Rate of Rise Heat Detector designed for use in hazardous areas. Incorporates a remote indicator output and a 60°C fixed temperature element.

- ▶ Twin fire LEDs allow 360° viewing
- ▶ Electronics free mounting base
- ▶ Remote indicator output
- ▶ ATEX certification to: II 1G EEx ia IIC T5 (Tamb=55°C)
- ▶ Suitable for installation in areas at Category 1 (inc all lower categories)
- ▶ Approved by LPCB, GL and to IECEx

⚓ DCD-E-IS

◆ DCD-1E-IS/SIL



YBN-R/4(IS)

A Conventional Detector Mounting Base associated with the CDX Range of Intrinsically Safe Detectors and is fully compatible with the majority of existing conventional fire alarm control panels.

- ▶ Low Profile, only 8mm
- ▶ Rugged design
- ▶ Dedicated cable screen terminal
- ▶ Accepts from 1 to 2.5mm² cables
- ▶ Quick connection via square cable clamps
- ▶ Electronics free
- ▶ GL Type approval

⚓ YBN-R/4(IS)

◆ YBN-R/4(IS)



CCP-E-IS

A Conventional Manual Call Point designed for use in hazardous areas and based upon the industry standard KAC world series housing.

- ▶ Terminals can accommodate up to a 2.5mm² solid conductor
- ▶ Approved to EN54 Part 12
- ▶ Rugged design
- ▶ GL Type approval
- ▶ ATEX Classification to: II 1G EEx ia IIC T4
- ▶ Supports either a 'Frangible Glass' element or a 'Non Frangible plastic' element

◆ CCP-E-IS/SIL



CCP-W-IS

An IP67 Conventional weatherproof call point designed for use in hazardous areas and based upon the industry standard KAC world series housing.

- ▶ Sealed to IP67
- ▶ Terminals can accommodate up to a 2.5mm² solid conductor
- ▶ Approved to EN54 Part 12
- ▶ Rugged design, with anti-tamper facility
- ▶ ATEX Classification to: II 1GD Ex ia IIC T4 Ga
- ▶ Supports either a 'Frangible Glass' element or a 'Non Frangible plastic' element

◆ CCP-W-IS/SIL

Lid Colours

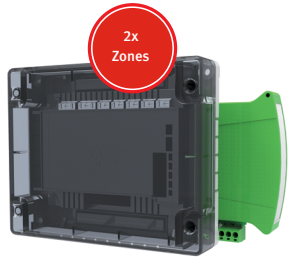

Lid Colours

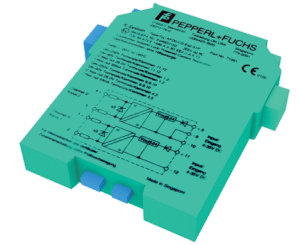
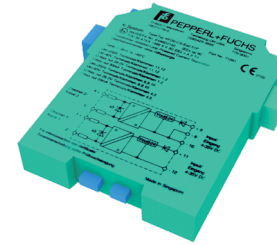
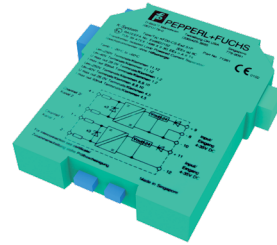
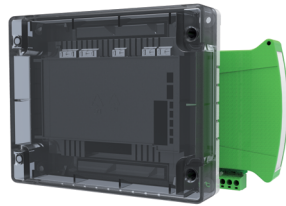

CHQ-DZM(SCI)-IS

A Dual Zone Module which is fully compatible with Hochiki's ESP analogue addressable protocol and I.S. equipment. The module will allow connection of up to 40 Hochiki I.S. conventional detectors (20 per zone) through a Galvanic isolator or Zener barrier, which are then fully monitored for open and short circuit. Also available as a DIN Rail mountable version. Both models feature an integral short-circuit isolator.

- ▶ Single loop address
- ▶ Supports two independent zones of Hochiki I.S. Conventional Detectors
- ▶ Both zones fully monitored for short/open-circuit
- ▶ Requires an auxiliary 24 VDC supply
- ▶ DIN rail version available
- ▶ Both models feature an integral short-circuit isolator
- ▶ Both models approved by LPCB
- ▶ Installed in safe area
- ▶ Can be used with CHQ-BACKBOX to comply with BS 7671

■ CHQ-DZM/DIN(SCI)-IS

CHQ-ISM

This Sounder Control Module interfaces between the Hochiki Analogue system via a CHQ-DSC2 or conventional sounder O/P's and the intrinsically safe sounder/beacon units via an intrinsically safe barrier.

The module provides line monitoring for open or short circuits on the wiring connected to both the safe and hazardous areas.

- ▶ Provides dual sounder circuits
- ▶ Fully monitored for short-circuits
- ▶ Requires 24 VDC external power supply
- ▶ Also available as a DIN module
- ▶ Installed in safe area
- ▶ Requires I.S. barrier
- ▶ Interfaces between loop and I.S. sounders/beacons
- ▶ Allows 1 I.S. Sounder or Beacon to be connected per circuit.
- ▶ Can be used with CHQ-BACKBOX to comply with BS 7671

◆ CHQ-ISM/SIL

■ CHQ-ISM/DIN

Z787

A Zener-Diode Barrier Dual channel, DC version, positive polarity, Working voltage 26.5 V at 10 μ A, Series resistance max. 327 Ω , Fuse rating 50 mA, DIN rail mounting, With diode return, Number of channels: channel-2, Type: DC, positive, Working voltage: max. 27 V.

- ▶ Simple installation onto standard DIN 'top-hat' railing
- ▶ Removable colour-coded terminals for easy connection
- ▶ Can accommodate conductors up to 2.5 mm²
- ▶ Supports two zones of I.S. products

Z728

A Zener-Diode Barrier 1-channel, DC version, positive polarity, Working voltage 26.5V at 10 μ A, Series resistance max. 327 Ω , Fuse rating 50 mA, DIN rail mounting, Number of channels: 1-channel, Type: DC, positive, Working voltage: max. 26.9 V.

- ▶ Simple installation onto standard DIN 'top-hat' railing
- ▶ Input circuit protected against reverse polarity
- ▶ Simplified installation and maintenance using plug-in connectors

KFDO-CS-EX2.51P

This Isolated Barrier is used for intrinsic safety applications. It transfers DC signals from fire alarms, smoke alarms, and temperature sensors in hazardous areas. It can also be used to control I/P converters, power solenoids, LEDs, and audible alarms.

- ▶ 2-channel isolated barrier
- ▶ Current input/output 0 mA to 40 mA
- ▶ I/P or transmitter power supply
- ▶ Accuracy 1%
- ▶ Reverse polarity protection
- ▶ Up to SIL2 acc. to IEC 61508



IFD-E(IS)

An Intrinsically Safe Conventional Infrared Flame Detector designed to respond to low-frequency (1 to 15Hz) flickering IR radiation emitted from flames during combustion, the unit can discriminate between flames and spurious sources of radiation such as sunlight.

- ▶ Unaffected by convection currents, draughts or wind and solar-blind
- ▶ ATEX certification to: EEx ia IIC T4 (135°C) (zones 0, 1 and 2)
- ▶ Selectable response speed
- ▶ Approved by LPCB
- ▶ SIL capable
- ▶ Mounting bracket available IFD-MB
- ▶ Responsive to a flame more than 25m away
- ▶ Class 1 performance as defined in BS EN54-10:2002 (on the high sensitivity setting)
- ▶ Tolerant of fumes, vapours, dust and mist



IFD-E(Exd)

A Conventional Explosion-Proof Infrared Flame Detector designed to respond to low-frequency (1 to 15Hz) flickering IR radiation emitted from flames during combustion, the unit can discriminate between flames and spurious sources of radiation such as sunlight.

- ▶ Unaffected by convection currents, draughts or wind and solar-blind
- ▶ ATEX certificated to: EEx d IIC T6 (85°C) (zones 1, 21, 2 and 22)
- ▶ Responsive to a flame more than 25m away
- ▶ Selectable response speed
- ▶ Approved by LPCB
- ▶ SIL capable



16091

A Hand Held Flame Detector Tester providing a flame-free method of UV testing the industrial IR³ series of flame detectors: IFD-E, IFD-E(IS) and the IFD-E(Exd).

THIS EQUIPMENT IS ALSO AVAILABLE FOR HIRE. Please contact your Sales Representative for further information.

- ▶ Tests many Flame Sensors Types UV, UV/IR, UV/IR², IR³, IR², IR
- ▶ Range typically 3m and beyond
- ▶ Selectable optical output intensity with LED bar graph indication
- ▶ Flame-free UV testing, ideal for hazardous areas
- ▶ Simple to use hand held unit with rechargeable NiCd battery pack and charger

FIREwave

Hybrid Wireless Fire Detection

Hochiki's FIREwave system raises wireless fire detection and alarm systems to new levels of reliability and flexibility. The hybrid system utilises the latest wireless technology to provide rapid, yet economic wireless fire system installations with the minimum of disturbance to the surroundings. Ideal for historic buildings, remote sites and any project where the installation of fire cabling is difficult, overly expensive or prohibited.

www.hochikieurope.com/firewave



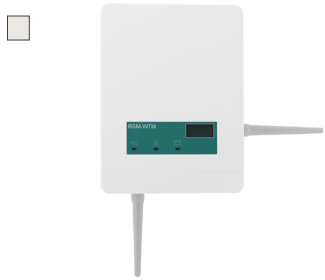

RSM-WTM

A Wire to Wireless Translator Module which allows a wireless fire detection system to be interfaced directly onto the loop. Fully loop-powered, the unit can support up to 32 wireless devices* and up to 7 RSM-EXP Expander Modules**.

- ▶ Loop Powered
- ▶ Bi-directional wireless communication
- ▶ Automatic wireless channel hopping
- ▶ Fully intelligent
- ▶ High reliability and sensitivity
- ▶ Flexible on site device adjustment
- ▶ IP65 protection for exterior mounting
- ▶ Makes additions to existing wired systems easy and cost effective
- ▶ LPCB approved
- ▶ Self optimising wireless amplitude and frequency

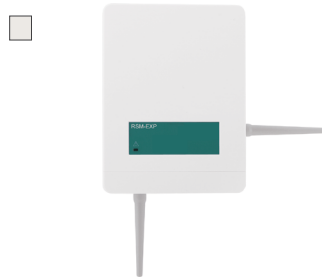

RSM-EXP

A Wireless Expander Module which allows extended signal coverage for the wireless system by boosting signal strengths from translators, to cover larger buildings for example. Up to 7 RSM-EXP Expander Modules** can be supported by a single RSM-WTM Wireless Translator Module.

- ▶ Bi-directional wireless communication
- ▶ Automatic wireless channel hopping
- ▶ Fully intelligent
- ▶ High reliability and sensitivity
- ▶ Flexible on site device adjustment
- ▶ IP65 protection for exterior mounting
- ▶ Makes additions to existing wired systems easy and cost effective
- ▶ Requires external power supply (24 VDC)
- ▶ LPCB approved
- ▶ Self optimising wireless amplitude and frequency

SYSTEM ARCHITECTURE

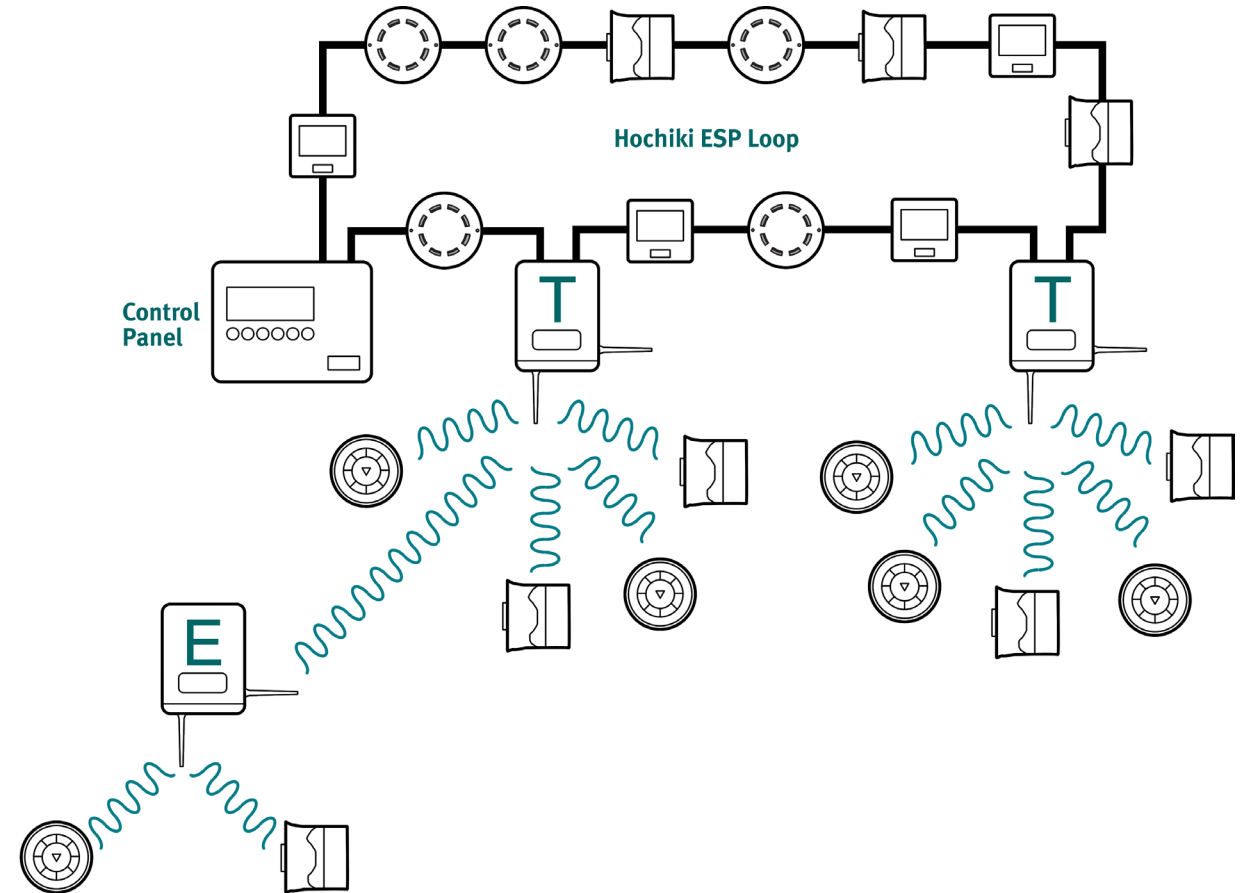

The RSM-WTM Translator Module (T) is fitted to the analogue addressable fire system loop. It then provides an interface between the loop and the wireless devices. The module is fully powered by the loop and full control and monitoring of the wireless devices is possible through the control panel.

The RSM-EXP Expander Module (E) allows the wireless system to provide greater coverage by receiving and re-transmitting the boosted wireless signal.

*Maximum number of 16 output devices such as A/V or output modules.

**Maximum of 5 child Expander Modules connected in cascade or a maximum of 3 child Expander Modules connected directly to the Translator Module or another Expander Module



RSM-CIM

A **Wireless Conventional Interface Module** which allows a zone of wireless devices to be added to an existing conventional zone (or as a stand-alone zone). The zone is wired directly to the RSM-CIM which is then in turn supported by an RSM-EXP Expander Module.

- ▶ Bi-directional wireless communication
- ▶ Automatic wireless channel hopping
- ▶ Fully intelligent
- ▶ High reliability and sensitivity
- ▶ Flexible on site device adjustment
- ▶ IP65 protection for exterior mounting
- ▶ Makes additions to existing wired systems easy and cost effective
- ▶ Requires external power supply for use as stand-alone zone
- ▶ Self optimising wireless amplitude and frequency



RSM-IP

A **Wireless Single Channel Input Module** which allows the on/off status (alarm/fault) of an external device to be transmitted to a control panel wirelessly via an RSM-CIM, RSM-EXP or RSM-WTM.

- ▶ Latching Input circuits are monitored for fire and fault conditions
- ▶ Bi-directional wireless communication
- ▶ Automatic wireless channel hopping
- ▶ Fully intelligent
- ▶ High reliability and sensitivity
- ▶ Flexible on site device adjustment
- ▶ Makes additions to existing wired systems easy and cost effective
- ▶ Self optimising wireless amplitude and frequency



RSM-POM

A **Wireless Powered Output Module** which allows the control panel to activate/switch the circuits of an external device or system wirelessly via an RSM-CIM, RSM-EXP or RSM-WTM. The unit's contacts can be configured to be normally open or normally closed and switch at 30 VDC/125 VAC at 2 A. The unit can be configured to provide either a 12 VDC or a 24 VDC output.

- ▶ Selectable output - 12 VDC or 24 VDC
- ▶ Bi-directional wireless communication
- ▶ Automatic wireless channel hopping
- ▶ Fully intelligent
- ▶ High reliability and sensitivity
- ▶ Flexible on site device adjustment
- ▶ Makes additions to existing wired systems easy and cost effective
- ▶ Self optimising wireless amplitude and frequency
- ▶ Contacts can be configured as N/O or N/C



RSM-CP

A **Wireless Resettable Manual Call Point** which features a simulated glass front. When activated, a plastic 'flag' is displayed in the window of the unit; the supplied key will reset the flag and unit. Supplied with back box. Weatherproof housing also available

- ▶ Bi Directional wireless communication
- ▶ Fully intelligent
- ▶ Utilises standard low cost lithium battery technology
- ▶ Long battery life
- ▶ Resettable Element
- ▶ Clear 'device activated' warning flag
- ▶ High reliability
- ▶ Automatic channel hopping
- ▶ Self optimising wireless amplitude and frequency



ROP-E

A **Wireless Dual Optical Smoke Sensor** which is fully intelligent device and compatible with FIREwave wireless Translator and Expander modules. The detector is designed for open area protection and utilises dual-path optical smoke detection technologies and algorithms for improved performance, whilst maintaining the high levels of unwanted alarm rejection. Utilising well proven adaptive radio signal processing algorithms ensure the highest levels of life safety and system reliability are achieved.

- ▶ Advanced dual path optical chamber design
- ▶ Internal algorithm processing optimises performance
- ▶ 3rd party approved
- ▶ Up to 10 year battery life
- ▶ Utilises standard low cost lithium battery technology
- ▶ Bi-directional wireless communications
- ▶ Compatible with all FIREwave Translators and Expanders
- ▶ Device identification tab
- ▶ Dual angle scattering analysis
- ▶ Fast test feature for engineer testing.



RHT-E

A Wireless Class P Heat Detector which is fully intelligent device and compatible with FIREwave wireless Translator and Expander modules. The detector is designed for open area protection and utilises dual-path optical smoke detection technologies and algorithms for improved performance, whilst maintaining the high levels of unwanted alarm rejection. Utilising well proven adaptive radio signal processing algorithms ensure the highest levels of life safety and system reliability are achieved.

- ▶ Twin alarm LEDs for 360 deg visibility
- ▶ Internal algorithm processing optimises performance
- ▶ 3rd party approved
- ▶ Up to 10 year battery life
- ▶ Utilises standard low cost lithium battery technology
- ▶ Bi-directional wireless communications
- ▶ Compatible with all FIREwave Translators and Expanders
- ▶ Multiple sensitivity settings
- ▶ Device identification tab.



RMC-E

A Wireless Multi-Criteria Detector which is fully intelligent device and compatible with FIREwave wireless Translator and Expander modules. The detector is designed for open area protection and utilises dual-path optical smoke detection technologies and algorithms for improved performance, whilst maintaining the high levels of unwanted alarm rejection. Utilising well proven adaptive radio signal processing algorithms ensure the highest levels of life safety and system reliability are achieved.

- ▶ Internal algorithm processing optimises performance
- ▶ 3rd party approved
- ▶ Up to 10 year battery life
- ▶ Utilises standard low cost lithium battery technology
- ▶ Multiple smoke and heat sensitivity setting
- ▶ Bi-directional wireless communications
- ▶ Compatible with all FIREwave Translators and Expanders
- ▶ Complies with the latest multi-sensor standard EN 54-295 year product warranty
- ▶ Twin alarm LEDs for 360° visibility.
- ▶ Advanced dual path optical chamber design



HFC-SBR-23-03

A Wireless Weatherproof Wall Sounder VAD The HFC-SBR-23-03 Wall Sounder VAD forms the core of our wireless EN54-23 modular visual alarm device (VAD) range. The unit comes with a wireless module HFW-SIM-01 which requires fitting into the Wall Sounder VAD back box. The HFC-SBR-23-03 is weather proof as standard and is equipped with 3 levels of volume adjustment, high output LED beacon and 32 recognised tones which can be set locally at the sounder.

- ▶ Flexible modular design
- ▶ 32 Tone Settings
- ▶ Two stage alarm capability
- ▶ Weatherproof as standard
- ▶ Easy to install
- ▶ Can be configured as Beacon only
- ▶ Microphone self test facility
- ▶ Also available in White
- ▶ Approved to EN54-3 and EN54-23 (W-2.5-7)



HFC-WSR-03

Wireless Weatherproof Wall Sounder The HFC-WSR-03 Wall Sounder forms the core of our wireless EN54-3 modular alarm device range. The unit comes with a wireless module HFW-SIM-01 which requires fitting into the Wall Sounder back box. The HFC-WSR-03 is weather proof as standard and is equipped with 3 levels of volume adjustment and 32 recognised tones which can be set locally at the sounder.

- ▶ Flexible modular design
- ▶ Approved to EN54-3
- ▶ 32 Tone Settings
- ▶ Two stage alarm capability
- ▶ Weatherproof as standard
- ▶ Easy to install
- ▶ Microphone self test facility
- ▶ Also available in white



RSM-BS

A Wireless Intelligent Base Sounder providing 32 tones as standard with a volume range of between 90.1 to 92.4 dB(A) at 1 metre. The pre-moulded base will accommodate any type of FIREwave wireless detector, or a locking cover plate (RSM-C).

- ▶ Bi-directional wireless communication
- ▶ Automatic wireless channel hopping
- ▶ LPCB approved
- ▶ 32 Tones, adjustable volume from 90.1 to 92.4 dB(A)
- ▶ Easy and cost-effective additions to existing wired systems
- ▶ Compliant with current EN54 European standards



RSM-BSB

A Wireless Intelligent Base Sounder Beacon providing 32 tones as standard with a volume range of between 90.1 to 92.4 dB(A) at 1 metre and a 1 Hz flash rate. The pre-moulded base will accommodate any type of FIREwave wireless detector, or a locking cover plate (RSM-C).

- ▶ Flash rate of 1 Hz
- ▶ Bi-directional wireless communication
- ▶ Automatic wireless channel hopping
- ▶ Compliant with current EN54 European standards and BS5839
- ▶ LPCB approved
- ▶ 32 Tones, adjustable volume from 90.1 to 92.4 dB(A)
- ▶ Easy and cost-effective additions to existing wired systems

*Note - Non EN54-23 Compliant (supplementary indicator)



HFW-DHR-01

A wireless magnetic door holder is compatible with all of the FIREwave Wireless Translator and Expander Modules enabling it to be easily integrated into a new or existing wireless system, linked to any wired system or even used as a standalone system. Its fully wireless and battery powered capability means it requires no wiring or power supply, making installation quick, easy and cost effective.

- ▶ Approved to BS EN 1155
- ▶ Easy and Fast installation
- ▶ Local door release button
- ▶ 5 year battery life
- ▶ Utilises standard low cost lithium battery technology
- ▶ Bi-directional wireless communications
- ▶ High holding force
- ▶ A Door closed monitoring option
- ▶ A Fail Safe monitoring to BS 7273 - 4:2015 cat. A, B & C



REPLACEMENT BATTERIES

Primary Battery

Spare Primary Battery (pack of 10)

Secondary Battery

Spare Secondary Battery (pack of 10)

FIRElink

Air Sampling System

Hochiki's FIRElink range of high sensitivity air sampling equipment consists of detectors and sampling pipe accessories to the very highest levels of sensitivity in environments such as computer areas and clean rooms. In these applications it is able to give warning to the very slightest trace of smoke. All detectors in the FIRElink range have been approved to EN54-20:2006 Classes A, B & C by LPCB.

www.hochikieurope.com/firelink





FIRElink-25

A Single Pipe Air Sampling Detector designed to provide very high sensitivity smoke detection. The unit will automatically setup for easy installation and is also designed to fit into a Docking Station which accepts all sampling pipes and cables leaving the detector to be fitted during the final commissioning phase.

- ▶ Approved LPCB
- ▶ False alarms reduced by unique dust discrimination
- ▶ RS485 communications for networking and remote communications
- ▶ Ultra small, low cost aspirating smoke detector
- ▶ Single sampling pipe up to 50m in length (still air)
- ▶ High sensitivity provided by laser based forward light scatter for reliable early warning



FIRElink-100

A Two Pipe Air Sampling Detector designed to provide very high sensitivity smoke detection. The unit will automatically setup for easy installation and is also designed to fit into a Docking Station which accepts all sampling pipes and cables leaving the detector to be fitted during the final commissioning phase.

- ▶ Approved LPCB
- ▶ Two sampling pipes up to 100m (aggregate) in length (still air)
- ▶ RS485 communications for networking and remote communications
- ▶ Ultra small, low cost aspirating smoke detector
- ▶ False alarms reduced by unique dust discrimination
- ▶ High sensitivity provided by laser based forward light scatter for reliable early warning



FIRElink-400

A Four Pipe Air Sampling Detector designed to provide very high sensitivity smoke detection with inherent immunity to dust/dirt build-up. Discriminates between 'dirty' and 'clean' operating periods such as day and night, automatically substituting appropriate system sensitivity without the need for external input or adjustment.

- ▶ Approved LPCB
- ▶ Four sampling pipes up to 200m (aggregate) in length (still air)
- ▶ RS485 communications for networking and remote communications
- ▶ False alarms reduced by unique dust discrimination
- ▶ High sensitivity provided by laser based light scatter for reliable early warning



FIRElink-400CM

A Four Pipe Air Sampling Detector with **integral Command Module** designed to provide very high sensitivity smoke detection with inherent immunity to dust/dirt build-up. Added "Command Module" allows the user to control, program and test other FIRElink units on the same "network".

- ▶ Approved LPCB
- ▶ Four sampling pipes up to 200m (aggregate) in length (still air)
- ▶ RS485 communications for networking and remote communications
- ▶ Command Module allows control over other FIRElink units on network
- ▶ False alarms reduced by unique dust discrimination
- ▶ High sensitivity provided by laser based light scatter for reliable early warning

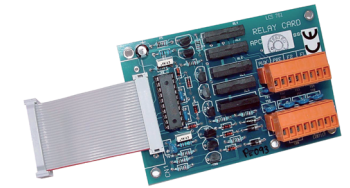

FL-RC

An Input Relay Card designed to provide detector inputs that may be programmed for Remote Day/Night Mode Changeover, Remote Reset or ClassiFire Override as well as power supply fault monitoring.

- ▶ Relay contacts rated at 0.4 A @24 VDC
- ▶ Common Fault relay energised normally closed for fail safe operation
- ▶ Only compatible with FIRElink-25 and FIRElink-100
- ▶ 4 staged normally open relay outputs for unmonitored connection to other systems

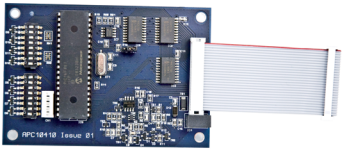

FL-APIC

An Addressable Protocol Interface Card used to decode and relay FIRElink detector information directly to an Hochiki ESP compliant Fire Control Panel.

- ▶ Full address range (1 - 127)
- ▶ Compatible with all FIRElink detectors and command modules
- ▶ Supports both single and multi mode operation



FIRElink Sampling Pipes

The sampling pipe and connectors are used in conjunction with the FIRElink Range of Air Sampling Detectors. The Pipe-cad software supplied with each FIRElink detector calculates the length of pipe and configuration of sampling holes required for each installation.

Prices and further details provided upon request.



FIRElink Dust Filters

FL-DF1 Hochiki Dust Filter For FIRElink 400 Series

FL-DF2 Hochiki Dust Filter For FIRElink 25/100 Series

Prices and further details provided upon request.

ANCILLARY

Equipment

Hochiki's comprehensive range of ancillary equipment includes products to help make routine maintenance and commissioning of analogue and conventional smoke detectors easier and more reliable. The range includes head removal tools, heat detector tester poles, loop commissioning and emulation equipment and duct smoke detection equipment.





DH-24

An Electromagnetic Door Holder designed to hold open fire doors and is ideally suited for hospitals, schools and other public buildings. In a fire situation the doors can be released automatically via a connection to the fire alarm system or manually by activating the release button.

- ▶ 24 VDC
- ▶ Surface mounted
- ▶ 200 Newton holding force
- ▶ Swivel keeper plate
- ▶ Spring-loaded ejector pin
- ▶ Manual release button



SDP-3

A Duct Probe Housing allowing a standard photoelectric smoke detection device, either a conventional detector or an analogue sensor, to be mounted on the outside of an air duct for the purpose of monitoring the air within the duct.

- ▶ One-tube air sampling system
- ▶ Test hole on cover
- ▶ Simple installation/maintenance
- ▶ Sensitive flow indication
- ▶ Installer-friendly connection of cables
- ▶ Allows air duct sampling using standard detector or sensor
- ▶ Fits either square or round section ducting (with additional brackets)



TCH-B200

A Hand Held Address Programmer designed to address the ESP range of Sensors and other intelligent devices such as the YBO-BS Base Sounder. Designed to be light, robust and easy to use it operates from a single PP3 size battery which can provide up to 8000 operations.

- ▶ Lightweight design
- ▶ Quick and reliable addressing
- ▶ Up to 8000 address settings from one battery
- ▶ Displays sensor analogue value



16091

A Hand Held Flame Detector Tester providing a flame-free method of UV testing the industrial IR³ series of flame detectors: IFD-E, IFD-E(IS) and the IFD-E(Exd).

THIS EQUIPMENT IS ALSO AVAILABLE FOR HIRE. Please contact your Sales Representative for further information.

- ▶ Simple to use hand held unit with rechargeable NiCd battery pack and charger
- ▶ Tests many Flame Sensors Types UV, UV/IR, UV/IR², IR³, IR², IR
- ▶ Range typically 3m and beyond
- ▶ Selectable optical output intensity with LED bar graph indication
- ▶ Flame-free UV testing, ideal for hazardous areas



YBN-UA

A Recess Mounting Adaptor for both the ESP and CDX Range of sensors and detectors and their associated mounting bases. Allows a base and head combination to be flush mounted by providing a recess fixing to the ceiling.

(Shown with base fitted – not supplied)

- ▶ Sturdy construction, easy to install
- ▶ Supplied with fixing brackets
- ▶ Colour-matched to existing ivory-coloured sensor/detector ranges
- ▶ Suitable for a maximum ceiling thickness of 30mm
- ▶ Allows base and analogue sensor or conventional detector to be flush mounted



YBD-RA

A **Surface Wiring Adaptor** which allows the majority of Hochiki Sensors/ Detectors and their Mounting Bases to be fitted flush against a fixing surface, whilst also allowing surface wiring (without conduit) to be connected.

- ▶ Low profile - only 16mm
- ▶ Compatible with the majority of existing Analogue and Conventional bases
- ▶ Colour matches standard Hochiki Analogue and Conventional sensor/ detector / base ranges



TE-TLE

A **Loop Emulator System** which consists of Software and a Hardware Interface that together allow a 'virtual' loop to be created on a PC connected to a Fire Alarm Control Panel. In this way, a complete fire detection system can be tested and proven before any actual hard-wiring commences, saving time and resources.

- ▶ Saves time and installation costs as the whole system can be tested 'virtually'
- ▶ Allows simulation of up to 4 loops of Hochiki analogue devices (127 per loop)
- ▶ System 'Cause and Effect' can be verified along with double address and circuit simulation



SOLO POLES

Fibreglass Poles designed to be completely interchangeable with all of the SOLO Tools. Manufactured in a lightweight fibreglass, the poles are completely non-conductive and have been subjected to rigorous conductivity testing to ensure the integrity of the insulating qualities.

- ▶ Lightweight, non conductive
- ▶ Accept all of the SOLO tools
- ▶ Can extend to 9m



TESTIFIRE

A fully portable field device for **functional testing of fire detectors**. The unit is suitable for testing optical/photoelectric and ionisation smoke sensors, thermal sensors (fixed temperature or rate-of-rise), and carbon monoxide (CO) fire sensors, be they conventional, addressable or analogue addressable.

- ▶ Powered by battery batons within pole
- ▶ Heat detector test times reduced through wider range of settings
- ▶ Clearing cycle provides rapid detector reset with no repeat alarm
- ▶ Stimuli capsules for smoke and CO held within unit
- ▶ Faster, more productive testing with just one tool
- ▶ Simultaneous stimuli (smoke and heat) can cut test times in multi-sensors by up to 66%



SOLO 200

A **Universal Detector Removal Tool** suitable for the majority of current Hochiki detectors*

*Except those with flying leads, for example the DFG-60E or the ACB-EW.

- ▶ Colour-coded grips twist into place to create different size combinations
- ▶ Universal, counterbalanced joint ensures the tool remains horizontal



SOLO 330

A **Smoke Detector Tester** providing functional testing to introduce (simulated) smoke or CO through the detector vents and into the sensing chamber.

- ▶ Robust, lightweight design
- ▶ Touch sensitive, ideal for suspended ceilings
- ▶ Clear cup allows view of detector LED
- ▶ Spring-loaded dispenser mechanism conserves aerosol
- ▶ Test gas canisters (non CFC) are available containing either simulated smoke (for testing smoke detectors) or CO (for testing CO detectors).



SOLO 423/424

A **Heat Detector Tester** mains-powered and available in both 110/120 and 220/240V versions.

- ▶ Initiates heat detectors into alarm, whether rate of rise or fixed.
- ▶ Comes complete with a 5m lead as standard (Optional 5m extension available)



SOLO 461

A **Cordless Heat Detector Tester** which utilises Cross Air Technology to ensure the correct temperature is applied to the sensing elements, not the detector plastics.

- ▶ Safe, cable free, battery-powered operation
- ▶ Supplied with 2 Battery Batons™ and a fast charger
- ▶ Intelligent device, only heats when detector present



SOLO 823 KIT

A **Universal Set Of Tools** for testing and removing smoke and heat detectors up to 9m high.

Contains:

- ▶ 1 x Solo 100 Telescopic Pole
- ▶ 3 x Solo 101 Extension Pole
- ▶ 1 x Solo 330 Aerosol Smoke Dispenser
- ▶ 1 x Solo 461 Cordless Heat Detector Test Kit (includes 2 Battery Batons™ and Charger)
- ▶ 1 x Solo 610 Protective Carrying Bag
- ▶ 1 x Solo 200 Universal Detector Removal Tool



HE-PSU(2.5A)

A **Stand-Alone Power Supply Unit** with integrated charger designed to be used with Hochiki's FIRElink range of air sampling detectors and the CHQ Modules that are non loop-powered (CHQ-DZM, CHQ-DZM(IS) and CHQ-DSC).

- ▶ Enclosure mounted with battery space
- ▶ Fully enclosed and robust construction
- ▶ 110 V or 230 V input
- ▶ Regulated, true 24 V output
- ▶ House up to 26 Ah batteries
- ▶ Status indicators for monitored faults
- ▶ Intelligent battery charging and temperature compensation
- ▶ Dual output for powering fire alarm control panels remotely



HE-PSU(5.25A)

A Stand-Alone Power Supply Unit with integrated charger designed to be used with Hochiki's FIRElink range of air sampling detectors and the CHQ Modules that are non loop-powered (CHQ-DZM, CHQ-DZM(IS) and CHQ-DSC2).

- ▶ Enclosure mounted with battery space
- ▶ 110 V or 230 V input
- ▶ Regulated, true 24 V output
- ▶ House up to 26 Ah batteries
- ▶ Status indicators for monitored faults
- ▶ Fully enclosed and robust construction
- ▶ Dual output for powering fire alarm control panels remotely
- ▶ Intelligent battery charging and temperature compensation



SMB-1

An IP66 Rated, Grey (RAL7035) Enclosure designed for use with the Hochiki range of Modules. Supplied with a transparent black lid as standard. Used in conjunction with the SMB-ADAPTOR this enclosure can house any of the PCB assemblies from the Hochiki Smart-Fix Module range.

- ▶ 32 knock-outs
- ▶ Grey lid available SMB-1(LID)
- ▶ Quick-release screws Polyurethane gasket provides IP66 protection
- ▶ Temperature resistance to +70°C, Impact resistant, and Non-flammable
- ▶ Corrosion free, resistant to most alkaline and acid

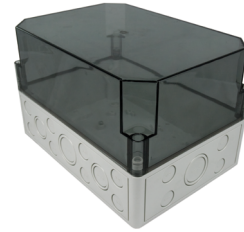

SMB-2

An IP66 Rated, Grey (RAL7035) Enclosure designed for use with the Hochiki range of DIN Modules. Supplied with a transparent black lid as standard. The unit is supplied with a DIN Rail section (plus fixings) and will accept up to six Hochiki DIN Rail Modules, side-by-side.

- ▶ Quick-release screws
- ▶ Polyurethane gasket provides IP66 protection
- ▶ 32 knock-outs
- ▶ Supplied with DIN Rail and fixings
- ▶ Grey lid available SMB-2(LID)
- ▶ Temperature resistance to +70°C, Impact resistant, and Non-flammable
- ▶ Corrosion free, resistant to most alkaline and acid
- ▶ Designed to house up to 6 Hochiki DIN Modules



SMB-3

A Grey (RAL7035) Enclosure Designed for use with the Hochiki range of DIN Modules. Supplied with a transparent black lid as standard. The unit is supplied with a DIN Rail section (plus fixings) and will accept up to four Hochiki DIN Rail Modules, side-by-side.

- ▶ 20 knock-outs
- ▶ Quick-release screws
- ▶ Polyurethane gasket provides IP66 protection
- ▶ Supplied with DIN Rail and fixings
- ▶ Grey lid available SMB-3(LID)
- ▶ Temperature resistance to +70°C, Impact resistant, and Non-flammable
- ▶ Corrosion free, resistant to most alkaline and acid
- ▶ Designed to house up to 4 Hochiki DIN Modules



PL-3

Additional Programming Lead 3 Way Connection For use on Hochiki devices that feature the square programming terminal, HCP-E(SCI) call points for example. The jack plug fits into the socket on the TCH-B200 programmer and the square programming plug fits to the device.

- ▶ Allows connection of TCH-B200 programmer
- ▶ For use with Hochiki devices with square connector

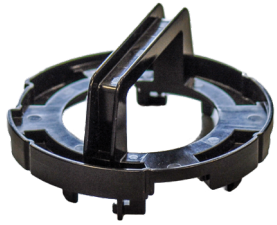

REMOVAL TOOL-3

Outer Cover Removal Tool allows the case of any photoelectric sensor or detector to be removed easily, even if the locking tabs have been employed. This allows easy access to the photoelectric chamber for maintenance or replacement. Fits ALN-EN, ACC-EN and ATJ-EN only.

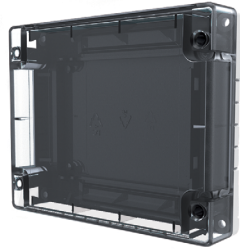

CHQ-SUB

The CHQ-SUB Assembly is a set of replacement components designed to fit any of the existing CHQ Modules: CHQ-DIM2(SCI), CHQ-SZM2(SCI), CHQ-DZM(SCI), CHQ-DSC2(SCI), CHQ-MRC2(SCI), CHQ-DRC2(SCI), CHQ-ISM & CHQ-PCM.

The sub-assembly consists of the PCB tray, PCB cover and semi-opaque lid and can be used in cases where an existing module housing becomes damaged and needs replacement.

- ▶ Used to replace damaged components
- ▶ Compatible with all CHQ Modules
- ▶ Robust design

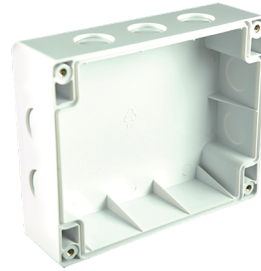

CHQ-BACKBOX

The Module Backbox is designed for installations where the CHQ Range of Modules - CHQ-DIM(SCI), CHQ-SZM(SCI), CHQ-DZM(SCI), CHQ-DSC(SCI), CHQ-MRC(SCI), CHQ-DRC(SCI) & CHQ-PCM require mounting within a glanded enclosure. The unit features ten knock-outs suitable for cable glands (not supplied) and accepts the CHQ Modules directly as a lid.

- ▶ Provides glanded cable connections
- ▶ Compatible with all CHQ Modules
- ▶ Robust design



CHQ-ADAPTER

Adaptor for the New CHQ Modules designed to allow the “Smart-Fix“ range of CHQ Modules to be housed in existing enclosures originally designed for the first generation CHQ-OEM Modules by modifying the ‘footprint’ of the unit.

- ▶ Footprint matches older enclosure sizes
- ▶ Allows the PCB component of a CHQ Module to be housed in an enclosure



MBB-2

A Marine Back Box providing a splash proof and secure fixing for the Hochiki ESP and CDX Marine Approved Range of Sensors and Detectors and their associated Bases. Provides an aesthetically pleasing solution where surface fixed devices are required. The housing supports four 20mm glanded entries for cabling access.

- ▶ 4 Glanded cable entry holes (glands not supplied)
- ▶ Colour matched
- ▶ Approved Sensor and Base range
- ▶ Provides moisture and dust resistant fixing
- ▶ Ideal for bulk-head fixing
- ▶ Approved to by GL
- ▶ GL Type approval
- ▶ Non-marine use version available (SBB-2)



SI-CAP2

A Protective Cap which can be fitted to the YBO-R/SCI isolator base range, the YBO-BS base sounder or the YBO-BSB base sounder beacon when either of these devices isn't fitted with a sensor. It can also fit the YBN-R/3 and the YBN-R/3(SCI).

- ▶ Easy to Fit (Twist-fit)
- ▶ Protects Wiring Terminals on Isolator Bases and Base Sounders

A Guide To Our Sounder/ Beacon Variants

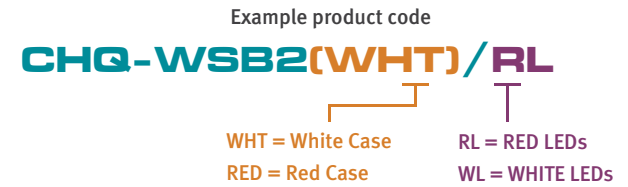

YBO-BSB2
An Addressable Loop-Powered
Base Sounder Beacon



CHQ-WSB2
An Addressable Loop-Powered
Wall Sounder Beacon

Product Type	Product Code	LED Colour	Case Colour	Rating
Base Sounder Beacon	YBO-BSB2/WL	White	Ivory	'0'
Base Sounder Beacon	YBO-BSB2/RL	Red	Ivory	'0'
Base Sounder Beacon	YBO-BSB2(WHT)/WL	White	White	'0'
Base Sounder Beacon	YBO-BSB2(WHT)/RL	Red	White	'0'

Product Type	Product Code	LED Colour	Case Colour	Rating
Wall Sounder Beacon	CHQ-WSB2/WL	White	Ivory	'0'
Wall Sounder Beacon	CHQ-WSB2/RL	Red	Ivory	'0'
Wall Sounder Beacon	CHQ-WSB2(WHT)/WL	White	White	'0'
Wall Sounder Beacon	CHQ-WSB2(WHT)/RL	Red	White	'0'

A Guide To Our Conventional Beacon Variants

Example product code

CWST-WR-S5

R = Red Case
W = White Case
R = Red LEDs
W = White LEDs
S = Standard Base
W = Weatherproof Base



CWST-S5
A Conventional Beacon



CWST-W5
A Conventional Weatherproof Beacon

Product Type	Product Code	Led Colour	Case Colour	EN54-23 Ratings			
				Wall Fitted	Ceiling Fitted		
Conventional Beacon	CWST-RR-W5	Red	Red	W-2.4-6.2	C-3-9.4	C-6-8.6	-
Conventional Beacon	CWST-RR-S5	Red	Red	W-2.4-6.2	C-3-9.4	C-6-8.6	-
Conventional Beacon	CWST-RW-S5	White	Red	W-2.4-9.0	C-3-9.5	C-6-9.5	C-9-9.5
Conventional Beacon	CWST-RW-W5	White	Red	W-2.4-9.0	C-3-9.5	C-6-9.5	C-9-9.5
Conventional Beacon	CWST-WR-S5	Red	White	W-2.4-6.2	C-3-9.4	C-6-8.6	-
Conventional Beacon	CWST-WR-W5	Red	White	W-2.4-6.2	C-3-9.4	C-6-8.6	-
Conventional Beacon	CWST-WW-W5	White	White	W-2.4-9.0	C-3-9.5	C-6-9.5	C-9-9.5
Conventional Beacon	CWST-WW-S5	White	White	W-2.4-9.0	C-3-9.5	C-6-9.5	C-9-9.5

A Guide To Our Ceiling Beacon Variants

Example product code

CHQ-CB(WHT)/WL

WHT = White Case
RED = Red Case

WL = WHITE LEDs
RL = RED LEDs



CHQ-CB

An Addressable Loop-Powered Ceiling Beacon

Product Type	Product Code	LED Colour	Case Colour	EN54-23 Ratings		
				0	1	2
Ceiling Beacon	CHQ-CB/WL	White	Ivory	C-3-5	C-3-7.5	C-3-10
Ceiling Beacon	CHQ-CB/WL-15	White	Ivory	0	C-3-10	C-3-15
Ceiling Beacon	CHQ-CB/RL	Red	Ivory	0	C-3-7.5	C-3-10
Ceiling Beacon	CHQ-CB (WHT)/WL	White	White	C-3-5	C-3-7.5	C-3-10
Ceiling Beacon	CHQ-CB (WHT)/WL-15	White	White	0	C-3-10	C-3-15
Ceiling Beacon	CHQ-CB (WHT)/RL	Red	White	0	C-3-7.5	C-3-10
Ceiling Beacon	CHQ-CB (RED)/WL	White	Red	C-3-5	C-3-7.5	C-3-10
Ceiling Beacon	CHQ-CB (RED)/WL-15	White	Red	0	C-3-10	C-3-15
Ceiling Beacon	CHQ-CB (WHT)/RL	Red	White	0	C-3-7.5	C-3-10

A Guide To Our Wall Beacon Variants

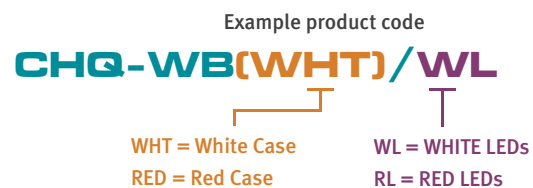

CHQ-WB
An Addressable Loop-Powered
Wall Beacon

Product Type	Product Code	LED Colour	Case Colour	EN54-23 Ratings		
				0	1	2
Wall Beacon	CHQ-WB/WL	White	Ivory	W-3-5	W-3-7.5	W-3.10
Wall Beacon	CHQ-WB/RL	Red	Ivory	W-3-5	W-3-7.5	W-3.10
Wall Beacon	CHQ-WB(WHT)/WL	White	White	W-3-5	W-3-7.5	W-3.10
Wall Beacon	CHQ-WB(WHT)/RL	Red	White	0	W-3.10	W-3.15
Wall Beacon	CHQ-WB(RED)/WL	White	Red	0	W-3.10	W-3.15
Wall Beacon	CHQ-WB(RED)/RL	Red	Red	0	W-3.10	W-3.15

**Current default setting light output level one.*

Guides from Hochiki



BS5839 Part 1:2017 Guide

Hochiki's BS 5839 Part 1:2017 pocket guide is designed to provide essential information for the selection, spacing and siting of fire detectors.

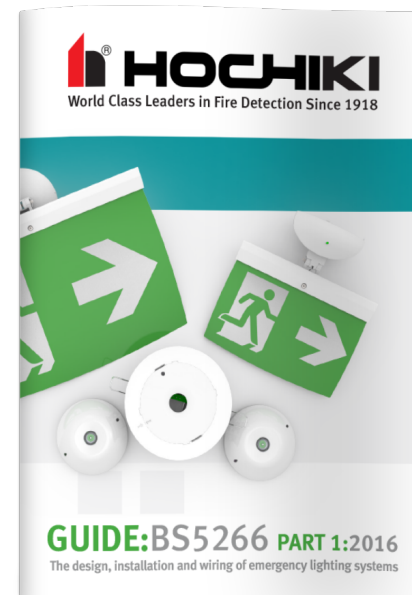

BS5266 Part 1:2016 Guide

Hochiki's BS 5266 Part 1: 2016 pocket guide is designed to provide essential information for the design, installation and wiring of emergency lighting products.

Index

16091	53, 62, 72	CHQ-SOM(HFP)	47	HFP CP	29	SR BACKBOX	49
16591	53	CHQ-SUB	76	HFP CP NETWORK DIAGRAM	30	TCH-B200	50, 72
ACB-EW	43	CHQ-SZM2/M(SCI)	49	HFP CP-XT	32	TESTIFIRE	73
ACC-E(HFP)	43	CHQ-SZM2(HFP)-SCI	49	HFP CP-XT +	34	TE-TLE	73
ACC-ENM	43	CHQ-WB(HFP)	46, 81	HFP CP-XTSI	36	YBD-RA	73
ACC-EN/SIL	43	CHQ-WPK	46	HFP PSU	40	YBN-R/3(HFP)	45
ACC-E(SCI)	44	CHQ-WS2	45	HFP REPEATERS	20	YBN-R/3M	45
ALN-E(HFP)	43	CHQ-WS2/SIL	45	IFD-E	53	YBN-R/3(SCI)	45
ALN-ENM	43	CHQ-WSB2	45, 78	IFD-E(Exd)	62	YBN-R/3(SCI)/SIL	45
ALN-EN/SIL	43	CHQ-WSB2/SIL	45	IFD-E(IS)	62	YBN-R/4(IS)	60
ALN-E(SCI)	44	CLB-E	56	KFDO-CS-EX2.51P	61	YBN-R/6(HFP)	54
ATJ-E(HFP)	43	CSBB-E	55	L@TITUDE ANALOGUE PANEL	8	YBN-R/6M	54
ATJ-ENM	43	CSB-E	55	L@TITUDE CONFIGURE	15	YBN-R/6SK	55
ATJ-EN/SIL	43	CWSB-E	55	L@TITUDE NETWORK DIAGRAM	16	YBN-UA	72
ATJ-E(SCI)	44	CWST-S5	57, 79	L@TITUDE REPEATERS	10	YBO-BS	46
BANSHEE EXCEL	56	CWST-W5	57, 79	L@TITUDE VIRTUAL RESOURCE	13	YBO-BSB2	46, 78
BANSHEE EXCEL IP66	56	DCD-1E-IS	60	MBB-2	76	YBO-R/3	45
BANSHEE EXCEL LITE	56	DCD-1E-IS/SIL	60	MBF-6EV	57	YBO-R/6(HFP)	54
BANSHEE EXCEL LITE IP66	56	DCD-A3M	52	PL-3	75	YBO-R/6PA	54
CCP-E	57	DCD-AE3(HFP)	52	PS200	50	YBO-R/6R(HFP)	54
CCP-E-IS	60	DCD-CE3(HFP)	52	REMOVAL TOOL-3	76	YBO-R/6RN	54
CCP-E-IS/SIL	60	DCD-CE3M	52	REPLACEMENT BATTERIES	67	YBO-R/6RS	55
CCP-KS	58	DCD-E-IS	60	RHD-E	66	YBV-R/4	44
CCP-SAWWIRE	58	DFJ-AE3(HFP)	52	RMD-E	66	Z728	61
CCP-W	58	DFJ-CE3	52	ROD-E	65	Z787	61
CCP-W-IS	60	DH-24	72	RSM-BS	66		
CCP-W-IS/SIL	60	DRD-E	53	RSM-BSB	67		
CHQ-ADAPTER	76	ESP FIREBEAM	44	RSM-CIM	65		
CHQ-ARI	47	FB/024/R/W	57	RSM-CP	65		
CHQ-BACKBOX	76	FIRElink-25	69	RSM-EXP	64		
CHQ-CB	46, 80	FIRElink-100	69	RSM-IP	65		
CHQ-DIM2/M(SCI)	48	FIRElink-400	69	RSM-POM	65		
CHQ-DIM2(HFP)-SCI	49	FIRElink-400CM	69	RSM-WTM	64		
CHQ-DIM2(SCI)/SIL	48	FIRElink Dust Filters	70	SDP-3	72		
CHQ-DRC2/M(SCI)	48	FIRElink Sampling Pipes	70	SI-CAP2	77		
CHQ-DRC2(HFP)-SCI	48	FL-APIC	70	SLR-E-IS	60		
CHQ-DRC2(SCI)/SIL	48	FL-DF1	70	SLR-E-IS/SIL	60		
CHQ-DSC2/M(SCI)	13	FL-DF2	70	SMB-1	75		
CHQ-DSC2(HFP)-SCI	49	FL-RC	69	SMB-2	75		
CHQ-DSC2(SCI)/SIL	49	HCP-EM(SCI)	49	SMB-3	75		
CHQ-DZM(HFP)-SCI	48	HCP-E(HFP)-SCI	49	SOC-E3N	52		
CHQ-DZM(SCI)-IS	61	HCP-E(SCI)/SIL	49	SOC-E3NM	52		
CHQ-ISM	61	HCP-WM(SCI)	49	SOLO 200	73		
CHQ-ISM/SIL	61	HCP-W(HFP)-SCI	49	SOLO 330	74		
CHQ-MRC2(HFP)-SCI	48	HCP-W(SCI)/SIL	49	SOLO 423/424	74		
CHQ-PCM(HFP)-SCI	48	HE-PSU(2.5A)	74	SOLO 461	74		
CHQ-PCM(SCI)/SIL	48	HE-PSU(5.25A)	75	SOLO 823 KIT	74		
CHQ-POM(HFP)	47	HFC-SBR-23-03	66	SOLO POLES	73		
CHQ-SIM(HFP)	47	HFC-WSR-03	66	SPC-ET	54		

Your Safety, Our Technology



Hochiki Asia Pacific PTE Ltd.

82 Ubi Ave 4
#06-02 Edward Boustead Centre
Singapore 408832
Tel: + 65 6841 9728
E-mail: hochiki@hochikiasiapacific.com
www.hochikiasiapacific.com

9-5-0-419/ISS13/OCT17

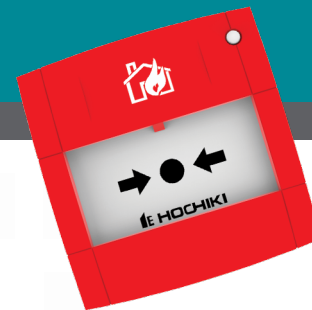

Quality Systems Certificate
No.164
Assessed to ISO 9001
Environmental Management
Certificate No. EMS 164
Assessed to ISO 14001



Registered to:
ISO 9001 • ISO 14001 • OHSAS 18001

